

Cladding tile Urban U / Urban L

Planning and installation





Table of contents

Application on the façade

General information	4
Products	5
Shapes / Formats	5
Technical data / Material requirements	5
System components	6
Planning	7
Basic principles	7
Principle	9
Substructure types	10
Example constructions	11
Colours and joint patterns	12
Division/spacing for vertical substructure	13
Construction details	14
Façade Base	16
Window Lintel	18
Building corners	19
Ridge details	20
Roof safety hook	21
Snow guard support	21
Installation	22
Instructions	22
Assembling the Omega system	23
Replacement and subsequent installation of individual tiles on the surface	27
Installing aluminium joint barriers	31
Installing a snow guard system	32
Tools / Machines	35
Cleaning	35
Maintenance	36
Requirements / Standards	36
Service	38

General information

This document provides information about the main aspects of planning and installation.

Further information can be obtained from:

Zürcher Ziegeleien AG
Eichwatt 1
CH-8105 Regensdorf
www.zz-ag.ch

Validity

At the time of carrying out the work, the most recent documentation is valid and can be obtained from the 'Downloads' area of www.zz-ag.ch.

The General Terms and Conditions of Zürcher Ziegeleien AG apply.
www.zz-ag.ch/agb

Product description

The Urban cladding tiles are innovative construction materials that unite aesthetics and functionality, bringing a tactile and textural character to buildings and the urban space. The fired clay tiles are produced industrially in their formats and shapes as ready-to-install cladding tiles. As well as being extremely easy to work with, the coarse ceramic material is the ideal sustainable product solution in a world where using limited resources responsibly is becoming ever more important.

Products

Shapes / Formats

Urban U

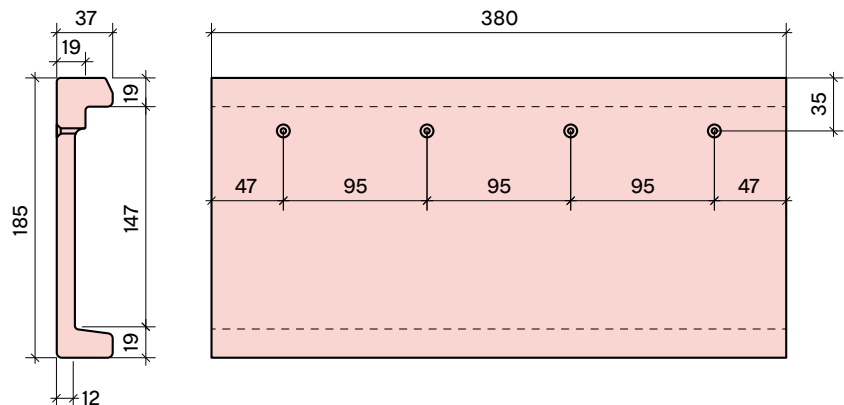

Urban L

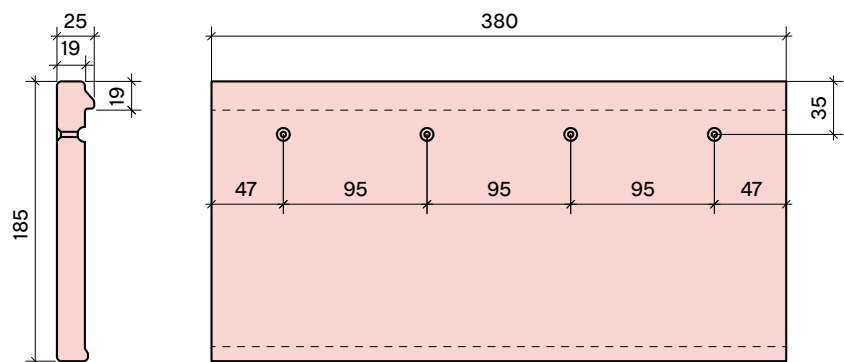

Technical data

Model	L-type
Colour	as per separate brochure / website
Length	185 mm
Width	380 mm
Height	25 mm
Wall thickness	19 mm
Batten spacing	81 - 142 mm (130)*
Tiles per m ²	18.5 - 32 tiles (20.2)* depending on batten spacing
Weight per tile	2.1 kg
Weight per m ²	38.8 - 68.0 kg (42.4) depending on batten spacing
Production tolerance	+/- 4%
Surface	roughened
Quantity per pallet	384 pcs
Weight per pallet	806.4 kg
Packaging	bundle of 8 pcs
Fixing	with screws
Frost resistance	EN 1304, EN 539-2
Content of active soluble salts	S2 as per EN 771-2

Model	U-type
Colour	as per separate brochure / website
Length	185 mm
Width	380 mm
Height	37 mm
Wall thickness	19 mm
Batten spacing	81 - 142 mm (130)*
Tiles per m ²	18.5 - 32 tiles (20.2)* depending on batten spacing
Weight per tile	2.17 kg
Weight per m ²	42.2 - 65.5 kg (43.8)* depending on batten spacing
Production tolerance	+/- 4%
Surface	roughened
Quantity per pallet	240 pcs
Weight per pallet	520.8 kg
Packaging	bundle of 5 pcs
Fixing	with screws
Frost resistance	EN 1304, EN 539-2
Content of active soluble salts	S2 as per EN 771-2

* Quantity with the standard batten spacing

Products

System components

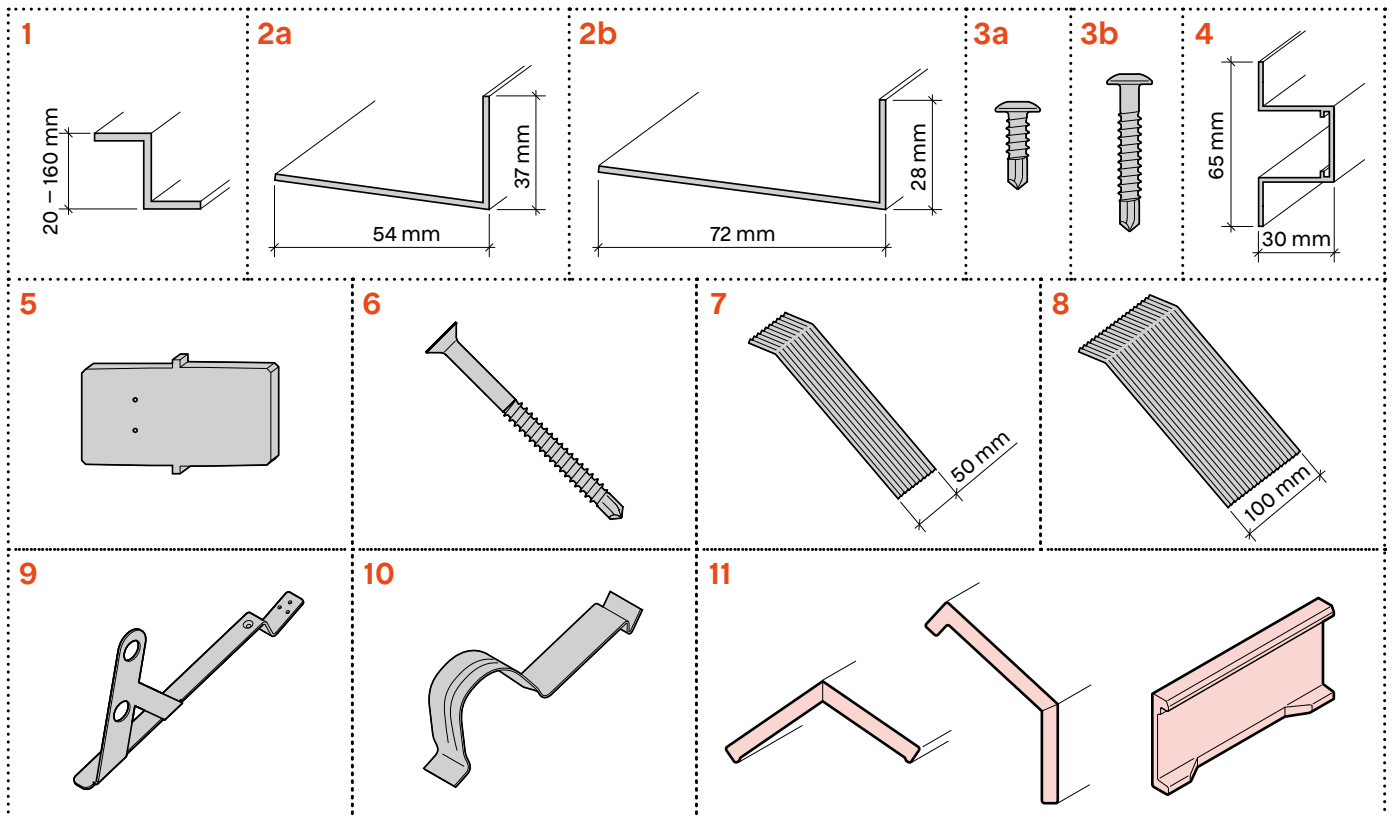

No.	Material code	Packing unit	Pcs/unit	Minimum sale unit	Quantity per m ² **	kg/pc
-----	---------------	--------------	----------	-------------------	--------------------------------	-------

Urban Omega system

1	Urban Z profile 20 – 160 mm (1 pc = 3 m)	Crate	–	1 Pc (3 m)	1.67m	–
2a	Urban Beginner 83 54 × 37mm (1 pc = 3 m)	Crate	480*	1 Pc (3 m)	0.44 m	1.56
2b	Urban Beginner U 72 × 28 mm (1 pc = 3 m)	Crate	350*	1 Pc (3 m)	0.44 m	1.56
3a	Urban self-drilling screw 4.8 × 16 mm	Carton	1000	1 Carton	25.64 pcs	0.003
3b	Urban self-drilling screw 4.8 × 30 mm	Carton	1000	1 Carton	25.64 pcs	0.003
4	Urban Omega-Profil (1 pc = 3 m)	Crate	210*	1 Pc (3 m)	7.69 m	1.95
5	Urban aluminium profile connector	Bag	100	1 Bag	2.56 pcs	0.032
6	Urban self-drilling screw 4.2 × 48 mm	Carton	1000	1 Carton	20.5 pcs	0.004

Special accessories

7	Aluminium joint barrier, coated 50 × 180 mm	Carton	1000	1 Carton	20.2	0.006
8	Aluminium joint barrier, coated 100 × 180 mm	Carton	1000	1 Carton	20.6	0.012
9	Urban snow guard support, anthracite	Pcs	1	1 Pc	individual	0.67
10	Urban Areto snow hook, anthracite	Bag	100	1 Bag	individual	0.071

Accessory tiles

11	Urban bespoke tile	Pcs	1	1 Pc	individual	individual
----	--------------------	-----	---	------	------------	------------

* Quantities per unit may differ slightly

** The quantity required depends on the batten spacing.

Planning

Basic principles

As the basis for planning, it is recommended to consult SIA standard 232 “Hinterlüftete Bekleidungen von Aussenwänden” (“Rear-ventilated cladding of external walls / rainscreen façades”) and SIA standard 118/232 “Allgemeine Bedingungen für geneigte Dächer und hinterlüftete Bekleidungen von Aussenwänden” (“General conditions for pitched roofs and rear-ventilated cladding of external walls”) from the Swiss Society of Engineers and Architects SIA. These standards define the current “codes of building practice” for rear-ventilated façades.

Building dilatation

In the case of structural dilatation joints, the façade substructures must also be continuously separated. Cladding tiles that are fitted over separation joints of support profiles must be fastened to only one of the support profiles in order to ensure that dilatation is not impeded. In the case of the Omega support battens made of aluminium, a spacing of 10 mm must be observed.

Rear ventilation

The spacing between the cladding and the layer behind, such as a facing sheet or thermal insulation, must be at least 20 mm in order to satisfy the basic requirement.

On timber substructures, wooden battens can significantly reduce the free cross-section of the ventilation space. This can be accounted for by increasing the width of the rear ventilation space.

Ventilation openings

In the case of façade cladding with butted/closed joints, ventilation openings must be created at the lowest and highest point of the façade in order to ensure sufficient rear ventilation.

Properly functioning rear ventilation also increases the lifespan of the cladding tiles and helps to keep the building cool in the summer.

The free ventilation cross-section must satisfy the following parameters:

- At least ½ the size of the rear ventilation cross-section
- At least 100 cm² per running metre
- Evenly distributed
- Reductions in the cross-section due to perforated plates, grilles and the like must be given due consideration (SIA standard 232/2). Perforated plates with a hole diameter of 5–8 mm are to be used.

Ideally, and wherever possible, window feed-throughs and the like should be provided with ventilation openings in the lintel area to let air in and openings under the windowsill to let air out.

Insulation / Breather membrane layer

It is recommended to use insulation that is hydrophobic or has a water-repellent non-woven fabric coating on its outer face.

The Urban cladding with a material thickness of 18 mm has a uniform joint ratio of < 3.5%. Therefore, according to SIA standard 232/2, Section 2.7.1, a facing sheet is not necessary.

Fire protection

Urban cladding tiles can be used on all possible building types. However, the correct substructure must be chosen. Façades with a rod-type timber substructure (support battens) are approved for buildings up to the high-rise limit (30 m total height). For higher buildings, non-flammable material must be used for the entire substructure. Suitable, approved aluminium components are available for such applications.

Structural analysis

A building-specific structural analysis is used to define the suitable primary substructure. This is the task and the responsibility of the architect/planner. Details of the component weights should be taken from the data sheets. If necessary, strength tests may be requested.

Planning

Principle

The Urban U and L cladding tiles are installed exclusively on horizontal support battens/ support profiles in the case of rear-ventilated façade systems, or on roofs. Each tile is secured with two screws.

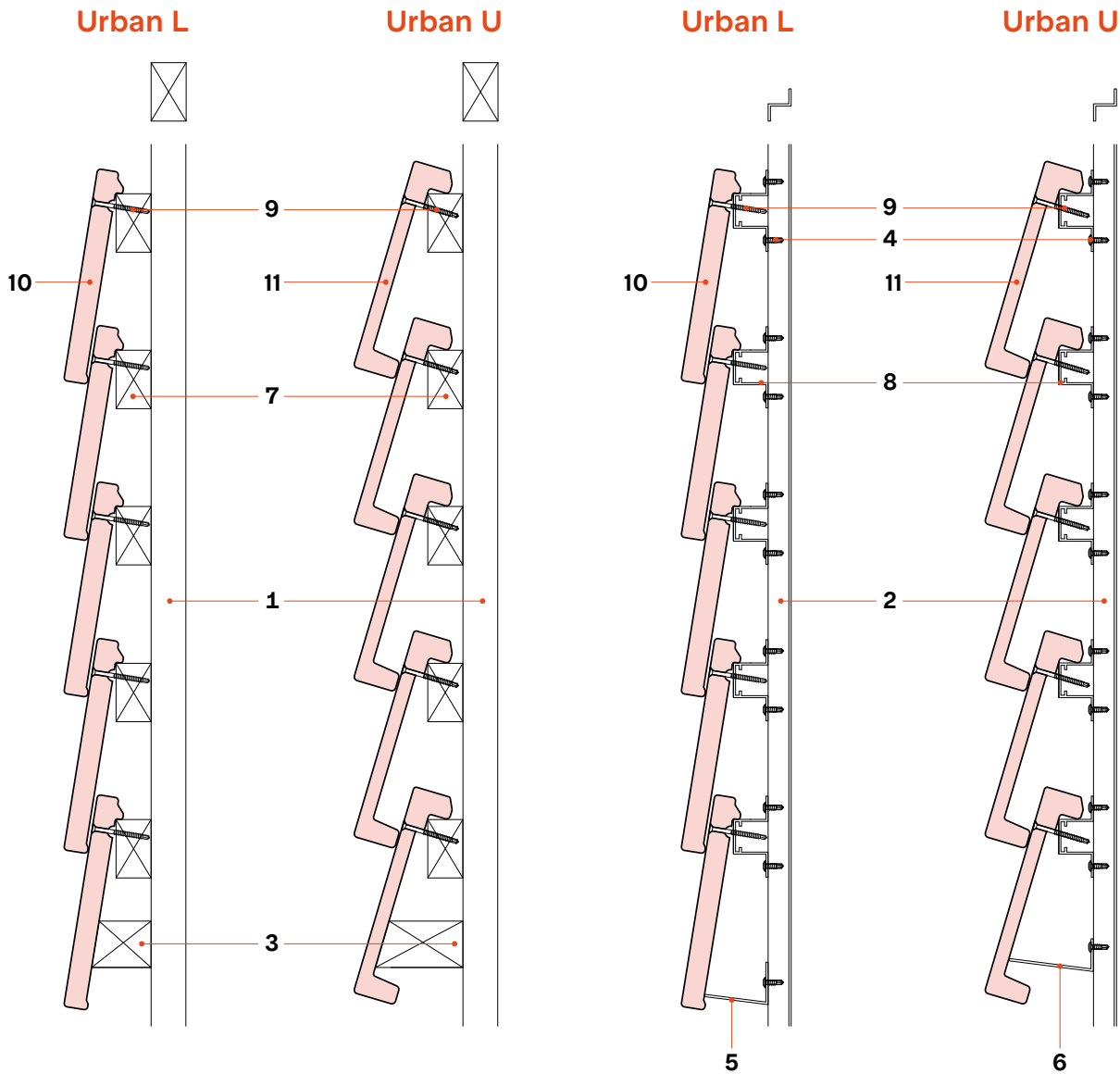

1	Rear ventilation battens / rear ventilation space / Counterbattens
2	Urban Z-profile / rear ventilation space
3	Beginner wooden batten
4	Urban self-drilling screw 4.8 x 16 mm
5	Urban Beginner profile 83 54/37 mm
6	Urban Beginner profile U 72/28 mm
7	Wooden support batten 30/50 mm
8	Urban Omega aluminium support batten 65/30 mm
9	Urban self-drilling screw 4.2 x 48 mm
10	Urban L cladding tile
11	Urban U cladding tile

Substructure types

The primary substructure (shown on this page in red) is the structural connection between the load-bearing external wall and the façade cladding. It consists of support profiles and wall brackets made of metal

(e.g. wall brackets with floating and fixed points made of aluminium, hot-dip galvanised or stainless steels) and/or wood (e.g. counter-battens/base battens, support battens, boarding/wood-based materials) or fibre-reinforced plastics.

The “Omega” support batten system is available from Zürcher Ziegeleien as an accessory for the Urban cladding tile. Standard commercially available products can be used for wall brackets etc.

Wood / Wood

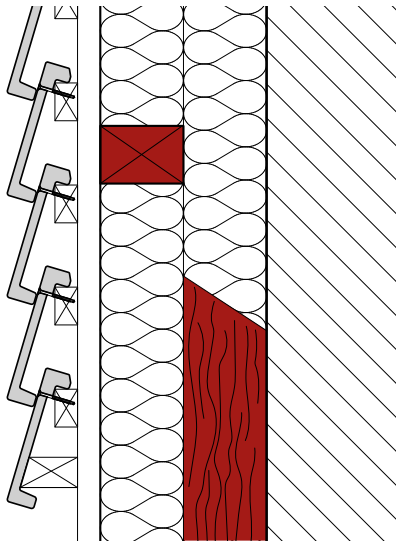

Metal / Metal

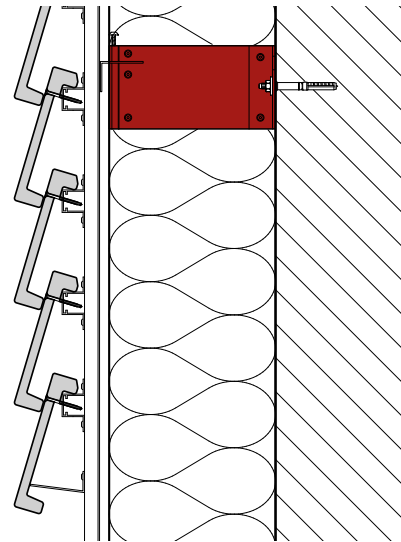

Timber frame construction

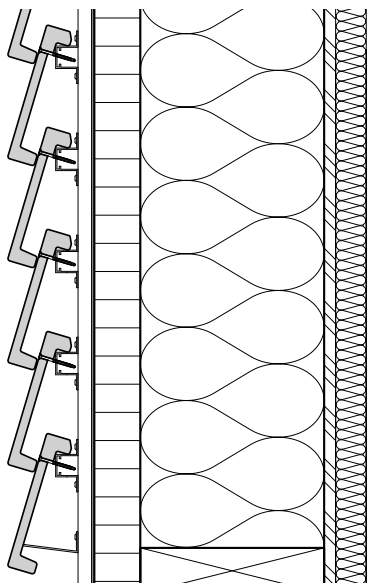

Wood / Spacer screws

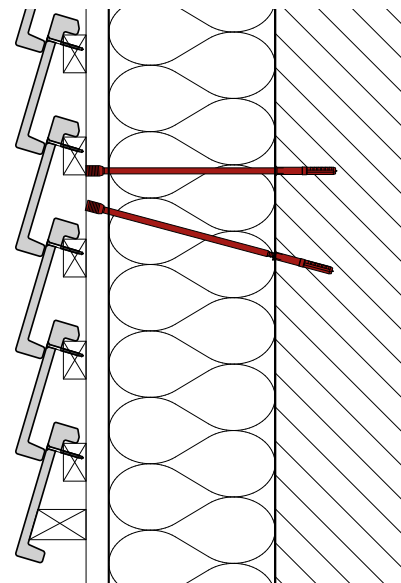

Example constructions

Wood / Wood

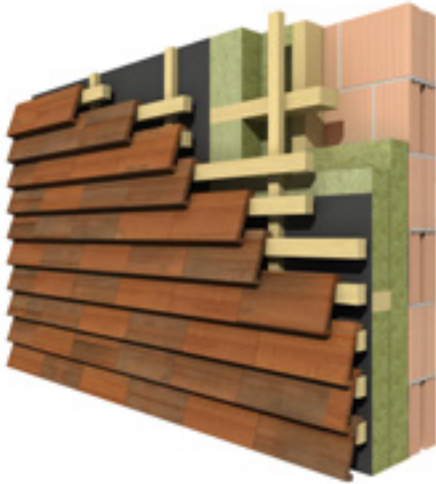

Façade structure

Traditional wall construction with a timber substructure; no special requirements concerning fire protection and only moderate thermal protection requirements.

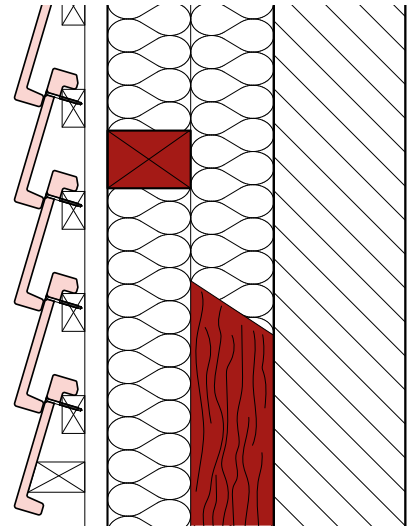

Metal



Façade structure

Façade structure with a metal substructure (façade brackets), including Thermostop element for high thermal protection requirements. This substructure is completely non-flammable and can be used above the high-rise limit.

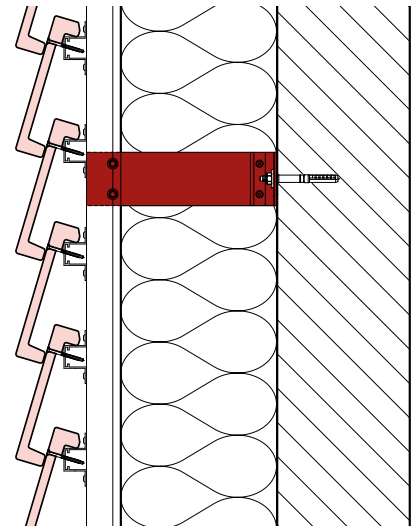

Roof

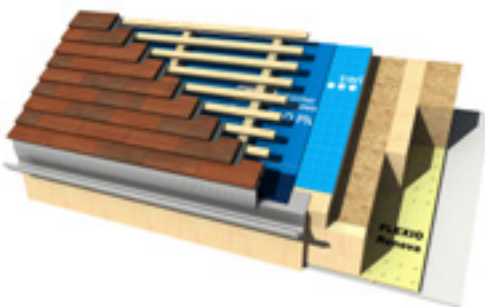

Roof structure

Urban cladding tiles can be used on roofs with a pitch of up to $>27^\circ$. The tile joints should be laid over coated system joint shingles made of aluminium. The sub-roof must be fitted according to the applicable extraordinary requirements.

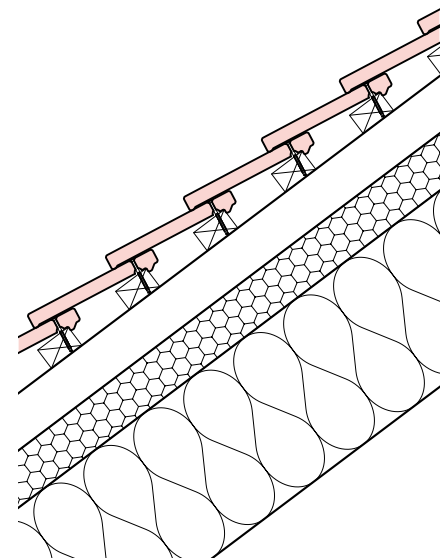

Colours and joint patterns

All colours can be downloaded from the website as a texture file.

Urban U



Frederiksberg

Christianshavn

Holmen

Rosenborg

Nordhavn

Urban L

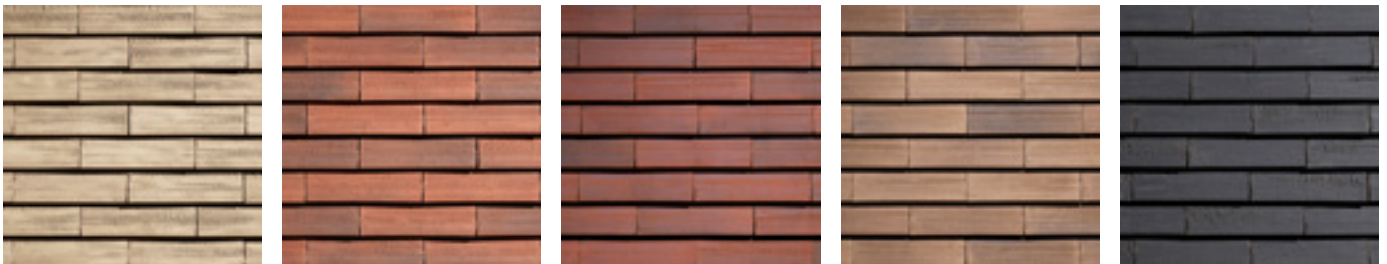

Frederiksberg

Christianshavn

Holmen

Rosenborg

Nordhavn

Colour variations

Coarse ceramic is a natural product, therefore slight colour variations are normal and are to be accepted. In order to achieve a natural colour effect, it is recommended to take tiles from at least 4 pallets at once and mix them in with one another.

Joint pattern options

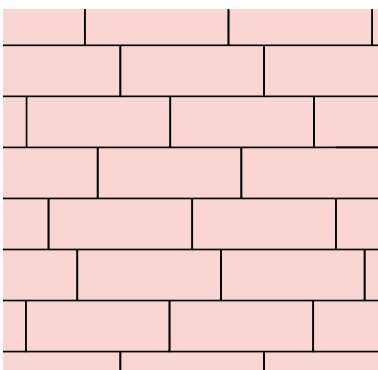

Irregular (random laying)

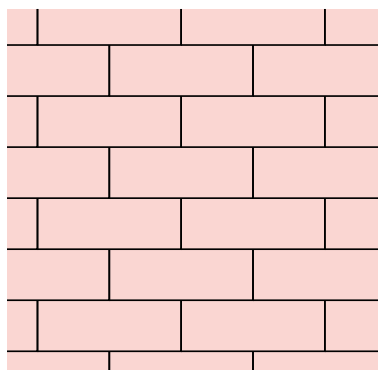

1/2 Bond

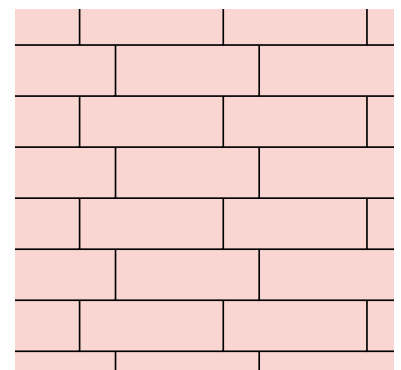

1/4 Bond

Recommendation: Random laying is the most installer-friendly method by far and creates less waste.

The length tolerances of the tiles may be up to +/- 10 mm.

Division/spacing for vertical substructure

Urban L

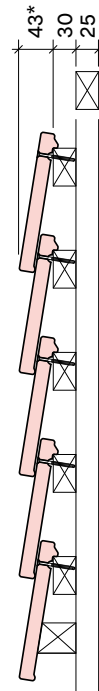
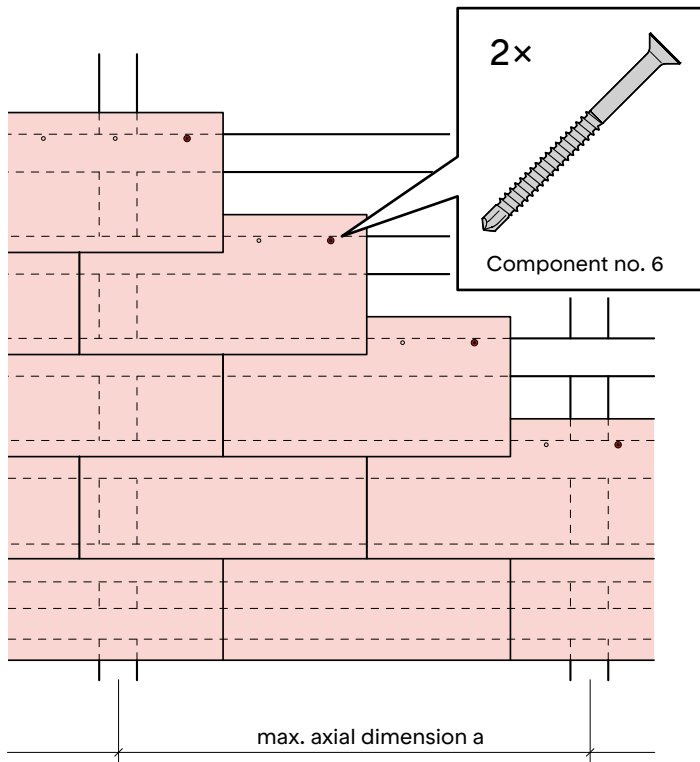

Substructure
wooden battens 30/50 mm
a = 680 mm

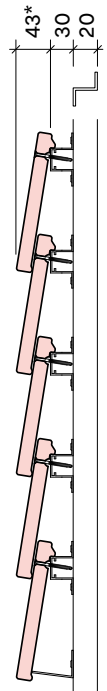

Substructure
Omega-profile
a = 680 mm

* Dimension depends on the batten spacing

Urban U

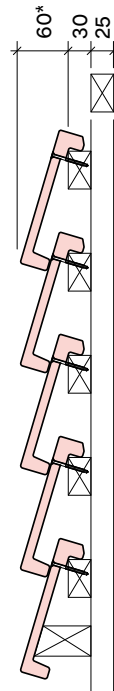
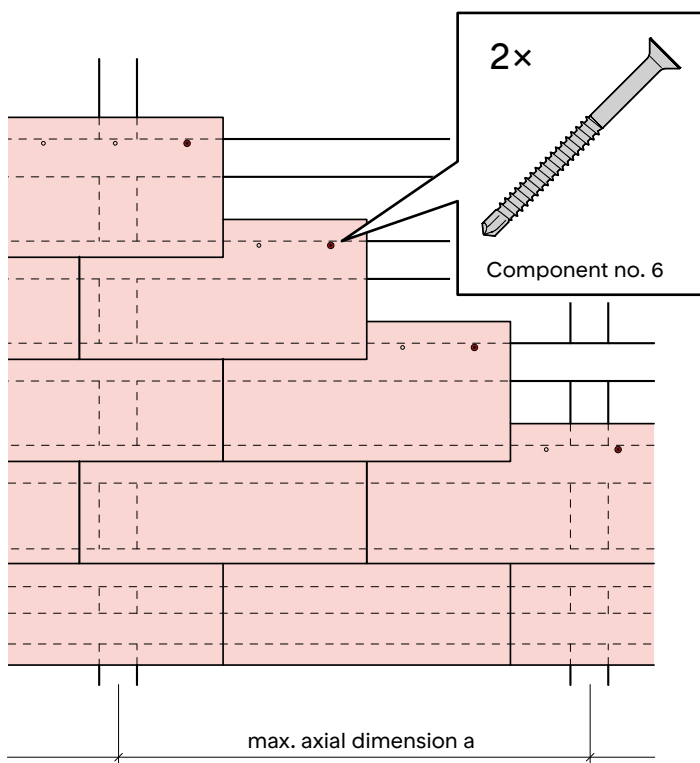

Substructure
30/50 mm
a = 630 mm

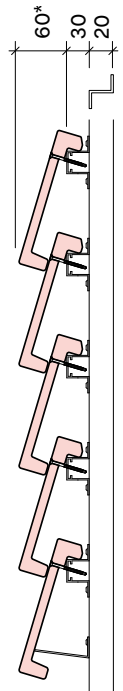

Substructure
Omega
a = 630 mm

* Dimension depends on the batten spacing

Construction details

Typical build up for Urban U (L on roofs)

Eaves detail and batten spacing

Every tile must be secured with two screws (stainless A4 4.2 x 48 mm)

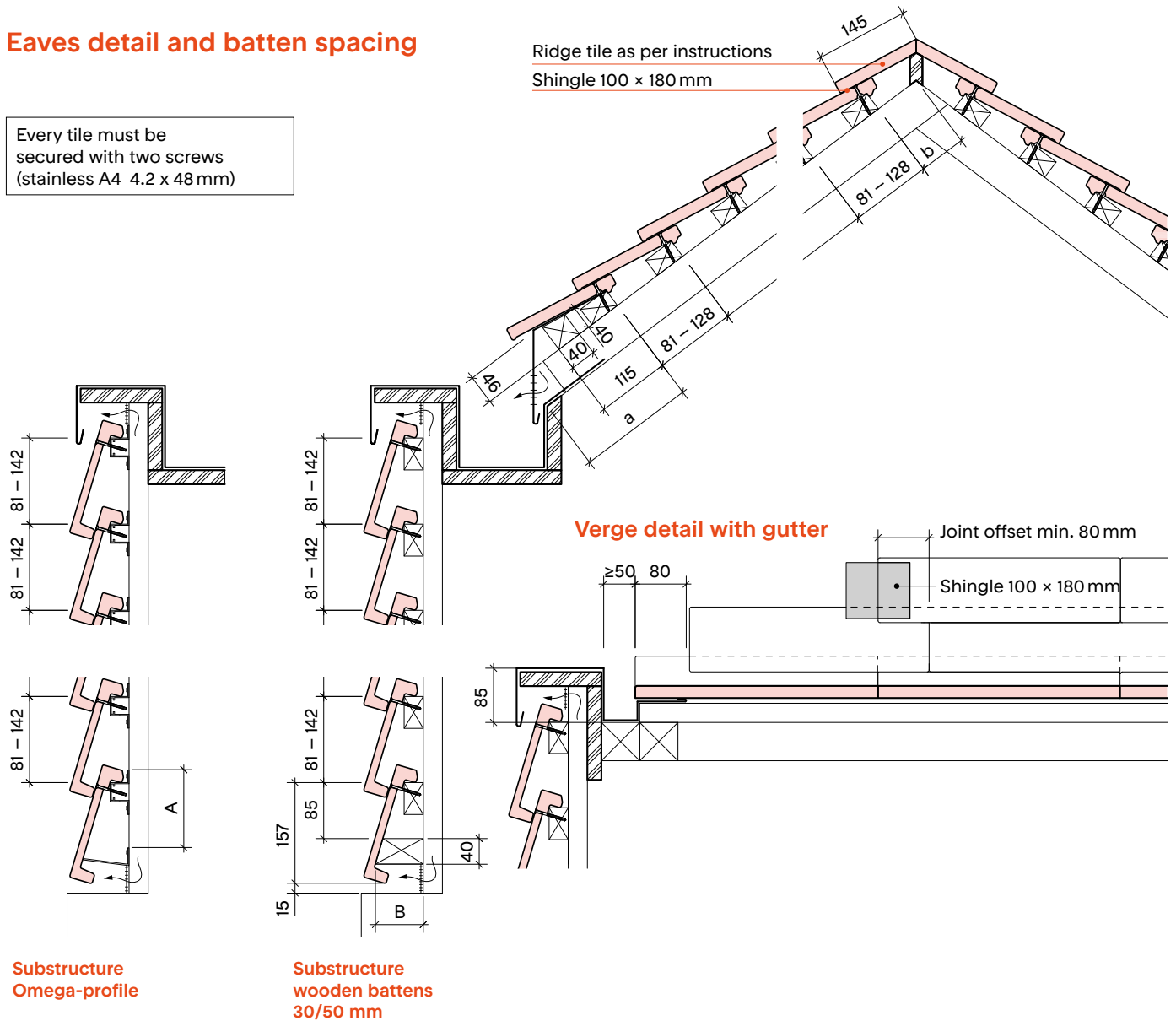

Dimensions table Urban Beginner U profile

General	Urban U	
	Dimension A	Dimension B
Batten spacing		
110	80	82
130	100	74
142	112	71

Suitability regarding reference height

As a general principle, up to a reference height of 1400 h_o(m) as per the snow load card from SIA 261 including correction rating and in compliance with SIA 232/1.

Minimum roof pitch, rafters

For installation on the roof, we recommend using Urban L.

Rafter pitch

Required ridge tile side 145 mm

Rafter pitch	Spacing b
30°	84 mm
40°	70 mm
50°	51 mm
60°	23 mm

Spacing a

Rafter pitch	Spacing a
30°	170 mm
40°	191 mm
50°	223 mm
60°	268 mm

Typical build up for Urban L

Eaves detail and batten spacing

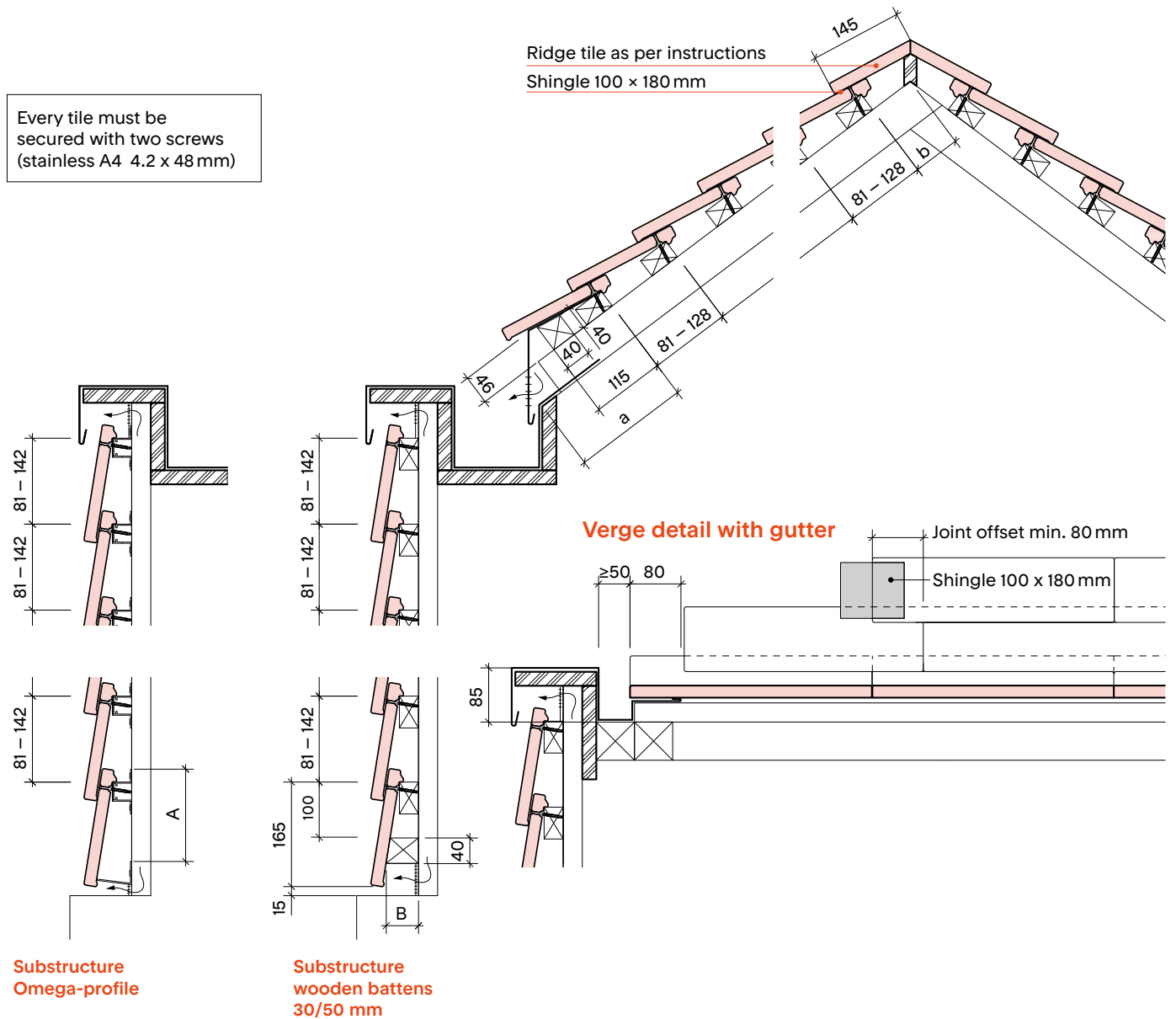

Dimensions table
Urban Beginner 83 profile

General	Urban L	
	Dimension A	Dimension B
Batten spacing		
110	104	57
130	134	53
142	139	51

Suitability regarding reference height

As a general principle, up to a reference height of 1400 h₀(m) as per the snow load card from SIA 261 including correction rating and in compliance with SIA 232/1.

Minimum roof pitch, rafters

Underlayer foil according: extraordinary load ≥ 27° (drainage into gutter required)

Rafter pitch

Required ridge tile side 145 mm

Rafter pitch	Spacing b
30°	84 mm
40°	70 mm
50°	51 mm
60°	23 mm

Spacing a

30°	170 mm
40°	191 mm
50°	223 mm
60°	268 mm

Façade Base

Scale 1:10

Urban U cladding tile

Metal substructure (facade brackets) with Thermostop element

Urban Omega aluminium support batten

Urban self-drilling screw 4.2 x 48 mm

Vertical profile/rear ventilation space

Insect screen

Urban Beginner profile

min. approx. 100 mm

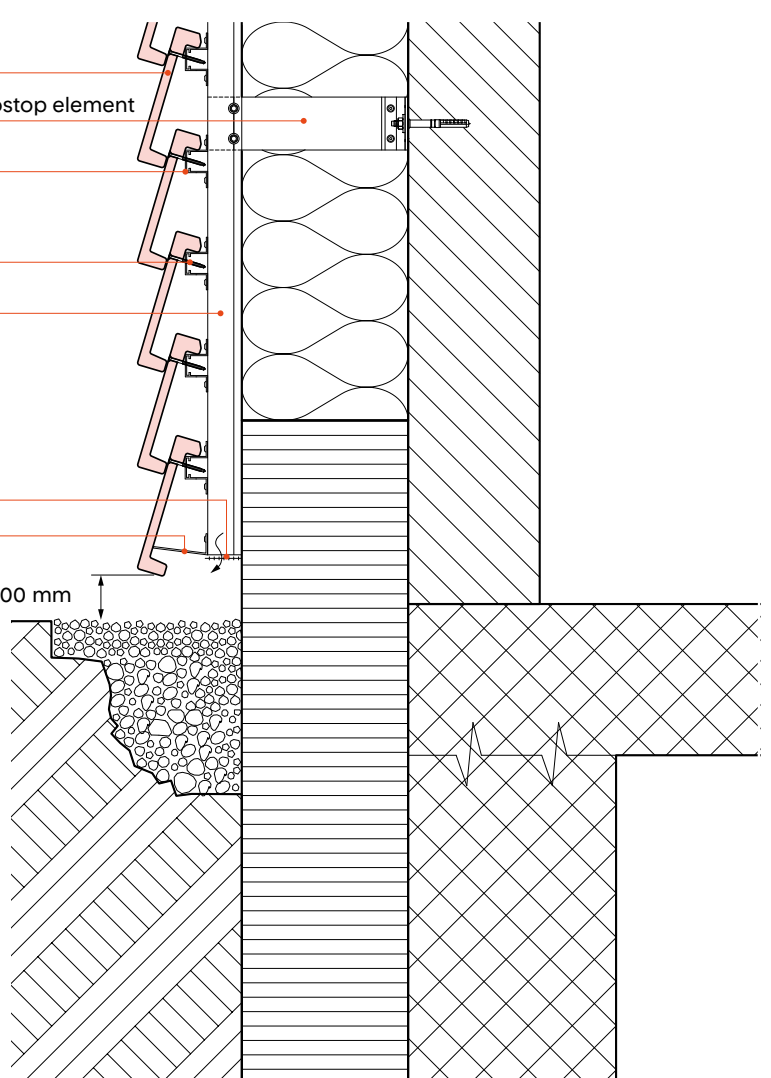

Urban L

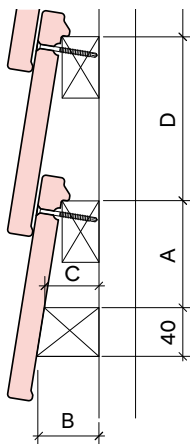

Urban U

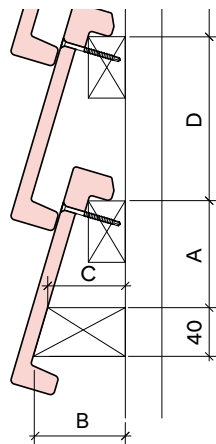

Urban L

Dimension A	Dimension B	Dimension C	Dimension D
100	51	45	142
100	53	46	130
100	57	49	110

Urban U

Dimension A	Dimension B	Dimension C	Dimension D
85	71	60	142
85	74	62	130
85	82	67	110

Façade Base

Scale 1:10

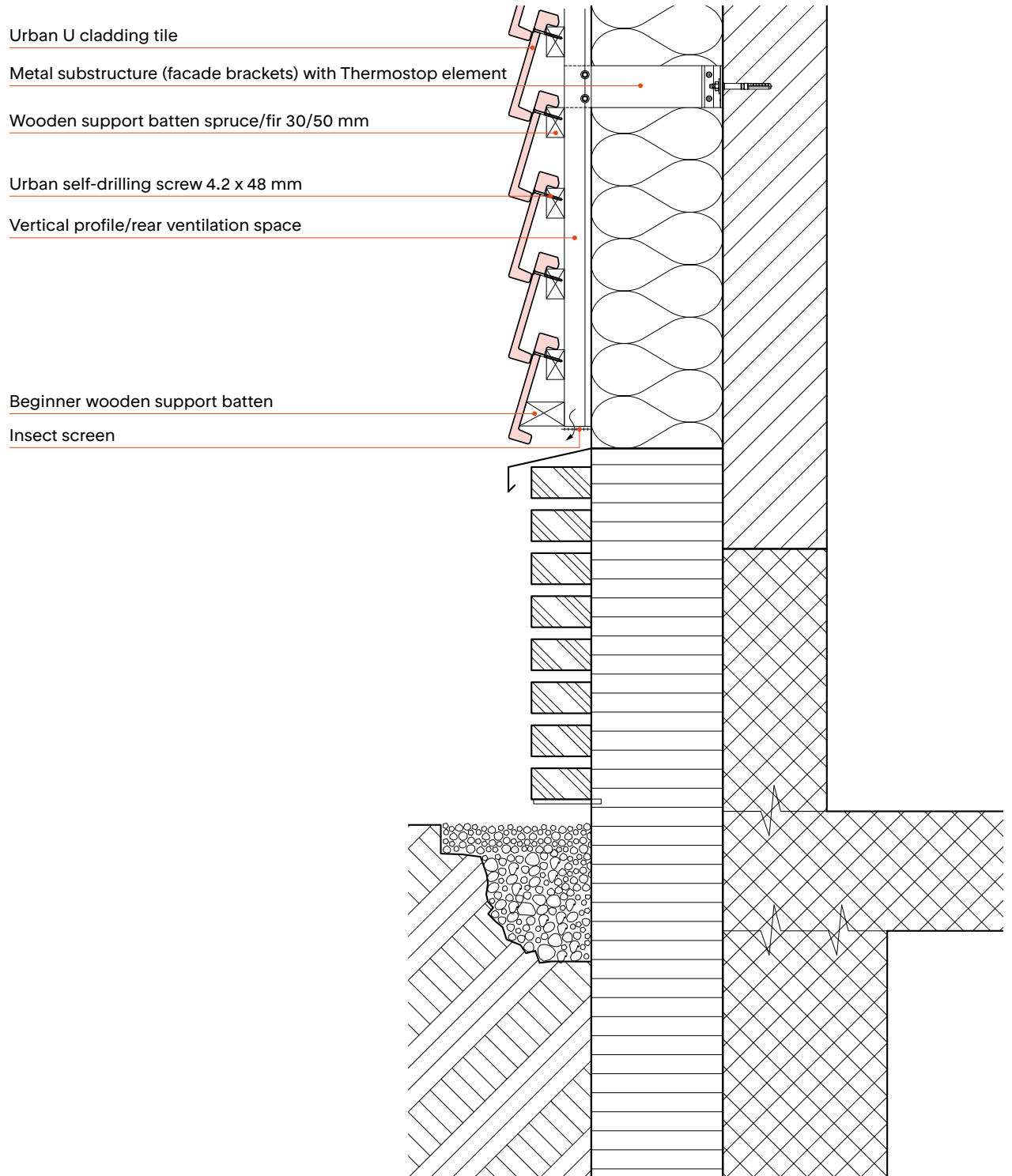

Window Lintel

Scale 1:10

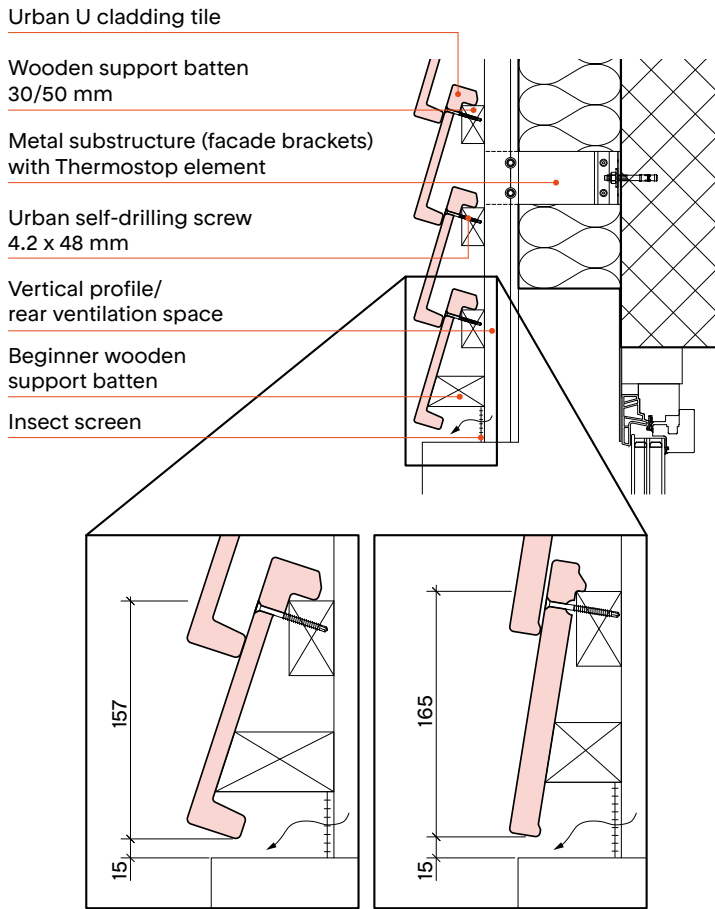

Urban U cladding tile

Wooden support batten
30/50 mm

Metal substructure (facade brackets)
with Thermostop element

Urban self-drilling screw
4.2 x 48 mm

Vertical profile/
rear ventilation space

Beginner wooden
support batten

Insect screen

157
15

165
15

Window jamb, horizontal section

Scale 1:10

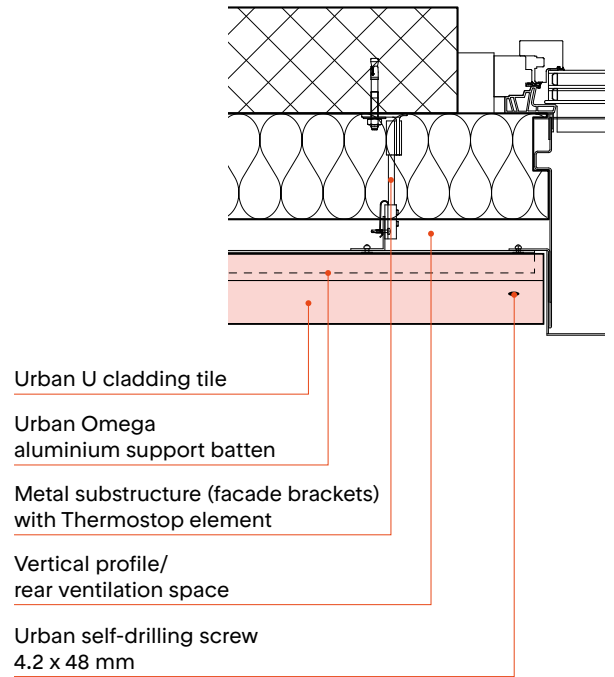

Urban U cladding tile

Urban Omega
aluminium support batten

Metal substructure (facade brackets)
with Thermostop element

Vertical profile/
rear ventilation space

Urban self-drilling screw
4.2 x 48 mm

Window Sill

Scale 1:10

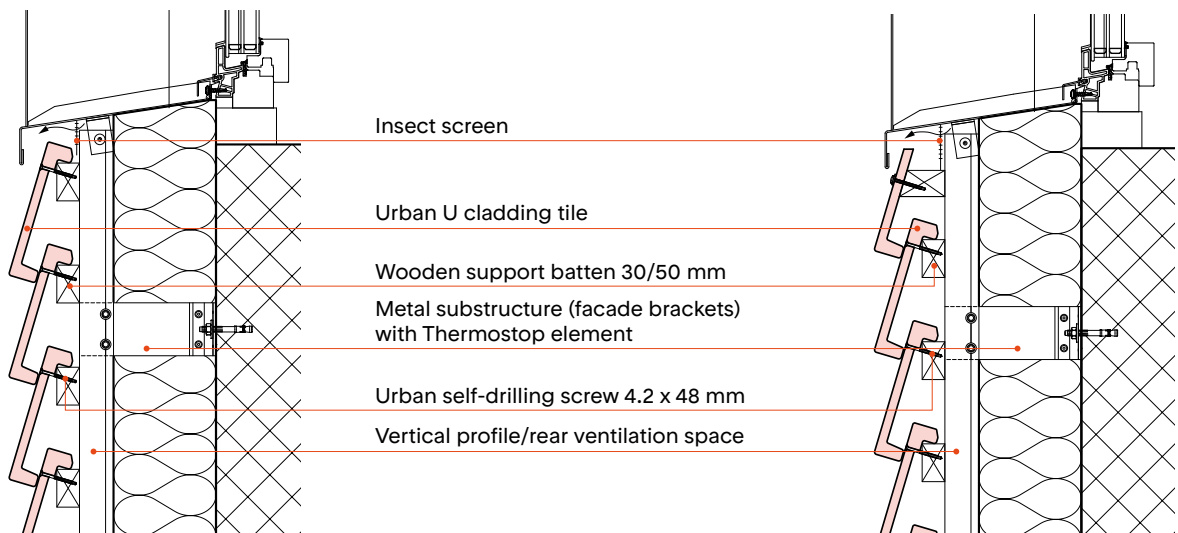

Insect screen

Urban U cladding tile

Wooden support batten 30/50 mm

Metal substructure (facade brackets)
with Thermostop element

Urban self-drilling screw 4.2 x 48 mm

Vertical profile/rear ventilation space

Inner building corner, horizontal section with aluminium substructure

Scale 1:10

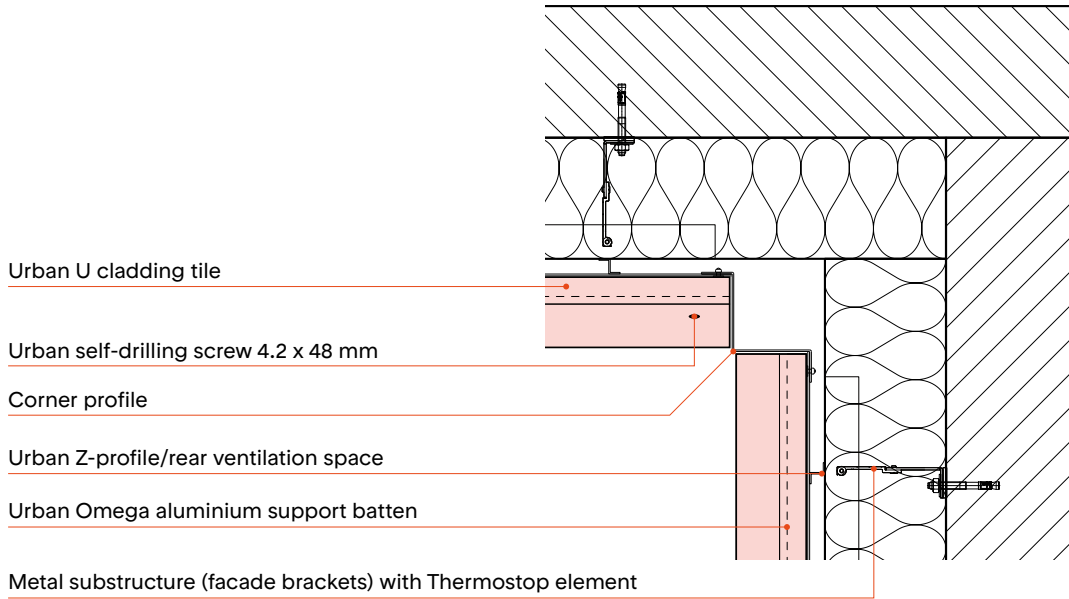

Outer building corner, horizontal sections

Scale 1:10

Bevel-cut tiles

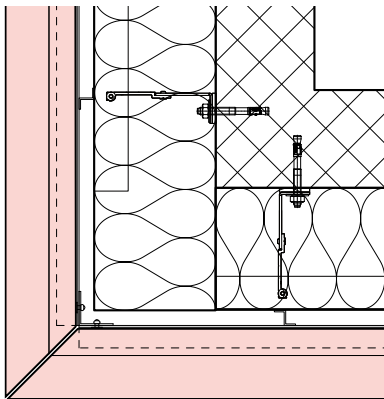

Cross-corner profile

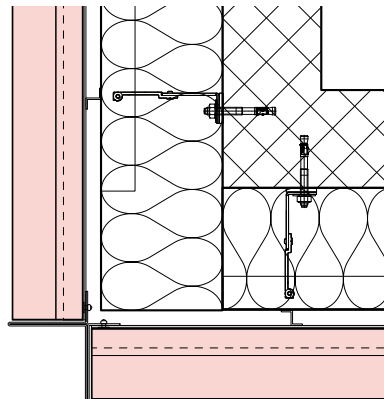

Spacer profile

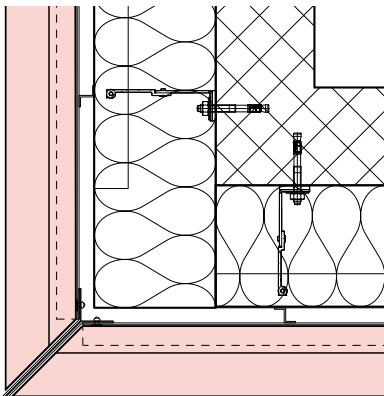

Cube corner profile

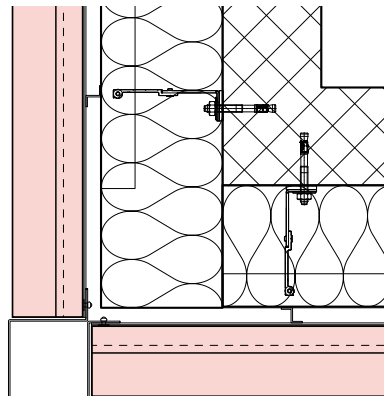

Ridge with ridge ventilation

Scale 1:5

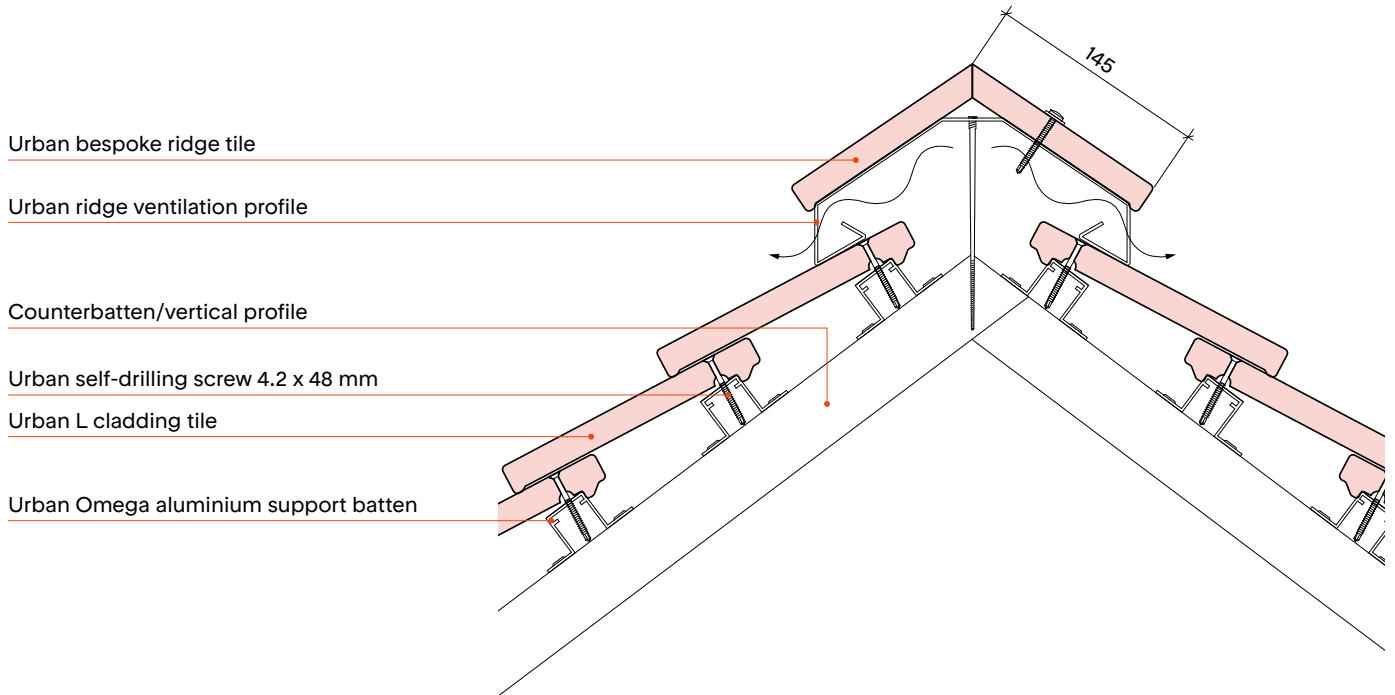

Flat roof detail

Scale 1:10

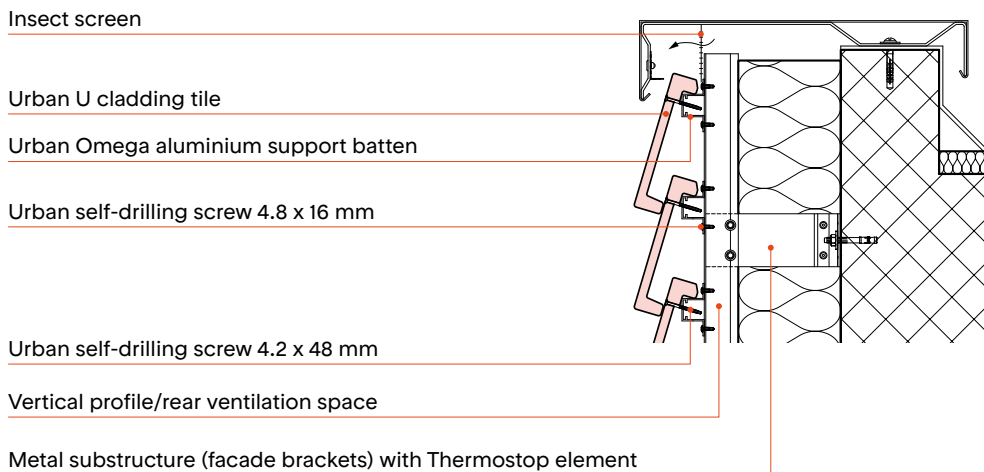

Roof safety hook

Scale 1:10

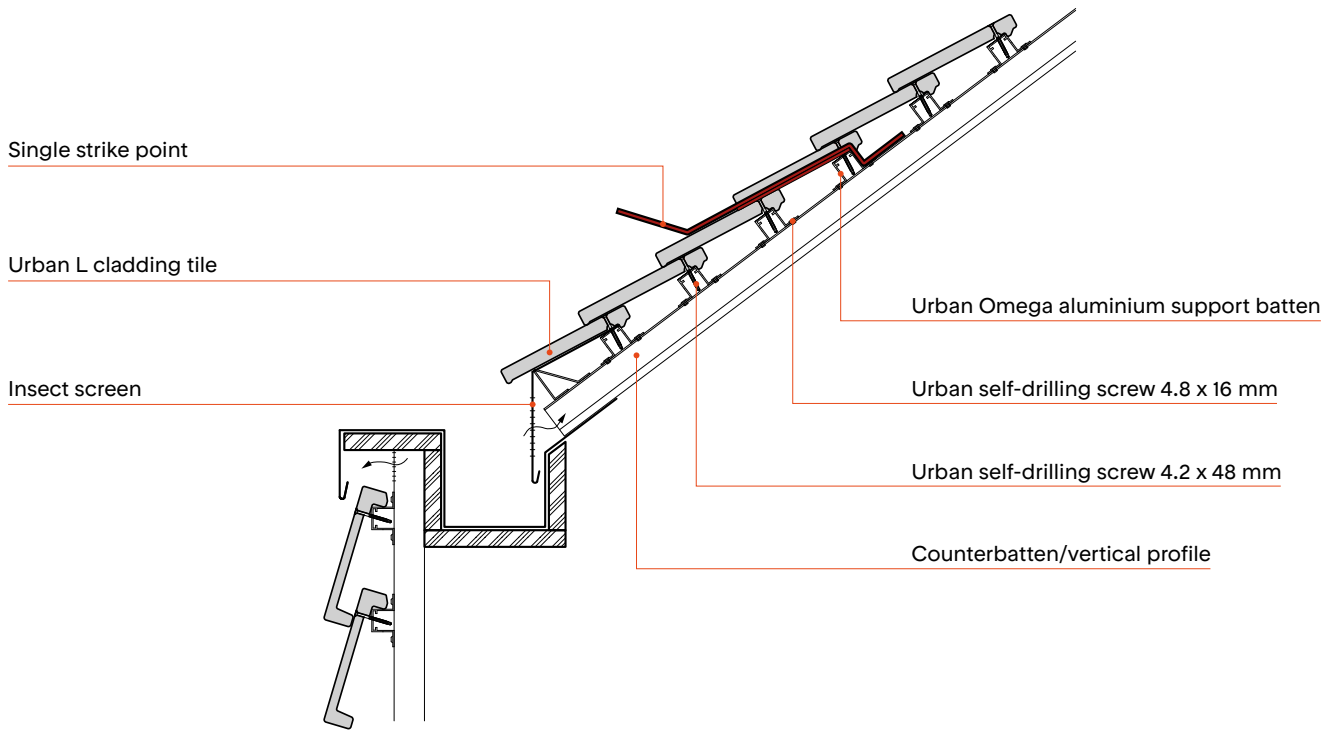

Snow guard support

(for low load $h_0 = < 800$ m)

Scale 1:10

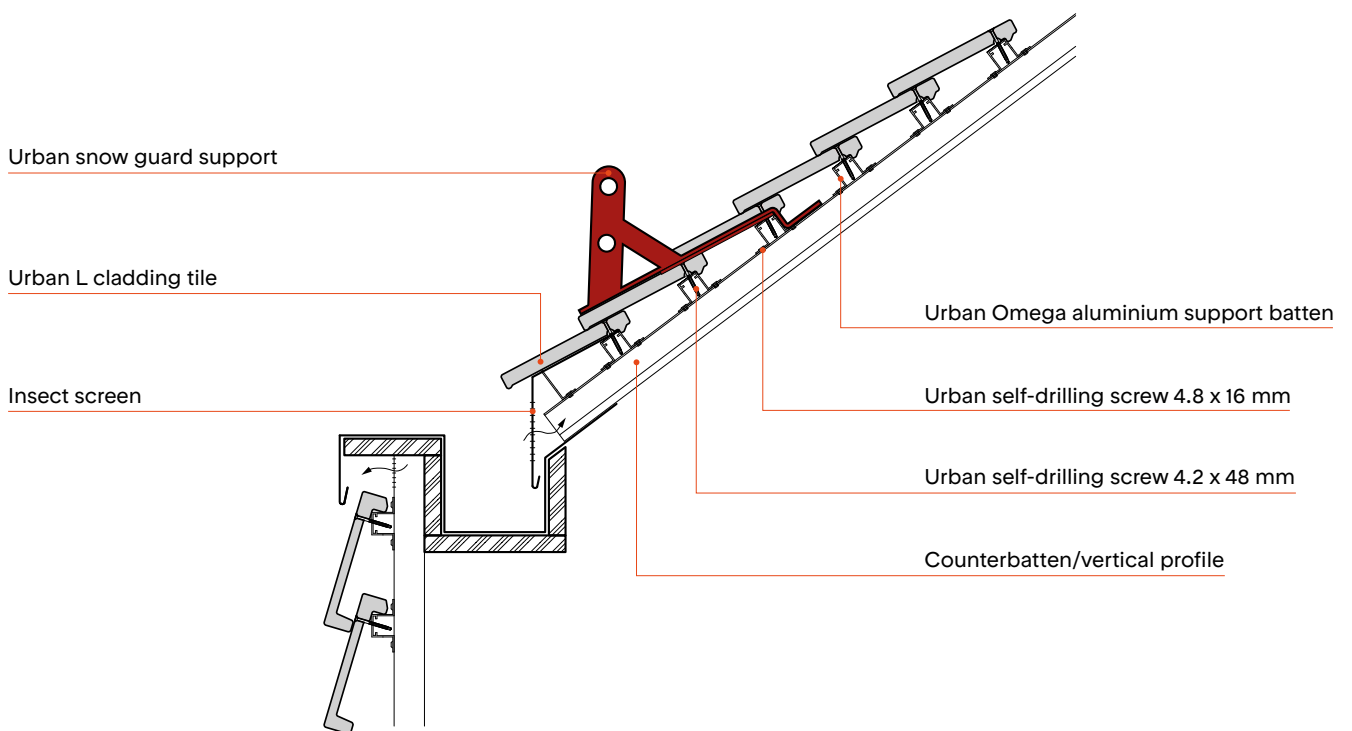

Installation

Instructions

Mounting the cladding tile

- Hook the Urban cladding tiles individually and with blunt sides lateral onto the batten/support profiles and secure immediately with 2 system screws. Joints should be a hair's breadth across.
- The sides of the tiles should not touch, and the tiles should be screwed onto the batten/support profile such that they cannot wobble but are not under tension.
- Take Urban cladding tiles from at least 4 different packs/pallets at once and mix them in with one another to achieve a natural colour effect.

Overlaps

Minimum overlap	Urban L	Urban U
Lateral joint overlap	≥ 80 mm	≥ 80 mm
Height overlap	≥ 33 mm	≥ 45 mm

Connections

- Minimum width of connecting tiles ≥ 100 mm
- Distance from drill hole to edge min. ≥ 15 mm
- In the case of side connections such as sheets, profiles and the like, the upper corners in the overlap area must be trimmed outwards at a 30° angle with an undercut.

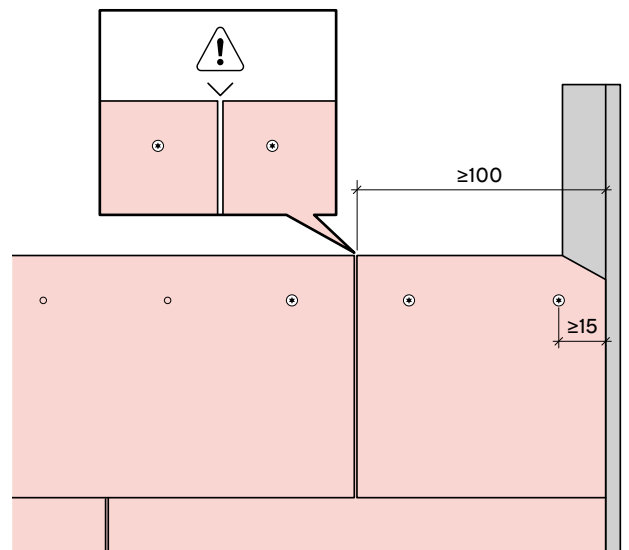

Storage/temporary storage at the building site

- Unload the Urban cladding tiles carefully, store them off the floor, and protect against dirt and weather exposure.
- If using covers such as tarpaulins, make sure that the stacked tiles still have adequate ventilation.
- The factory packaging is for protection during transport and does not offer protection against the weather.
- Pallets must not be stacked for transport.
- Up to 4 pallets may be stacked for storage.

Assembling the Omega system

1. Z-profiles are available for use as vertical rear ventilation battens. They are an optional element.

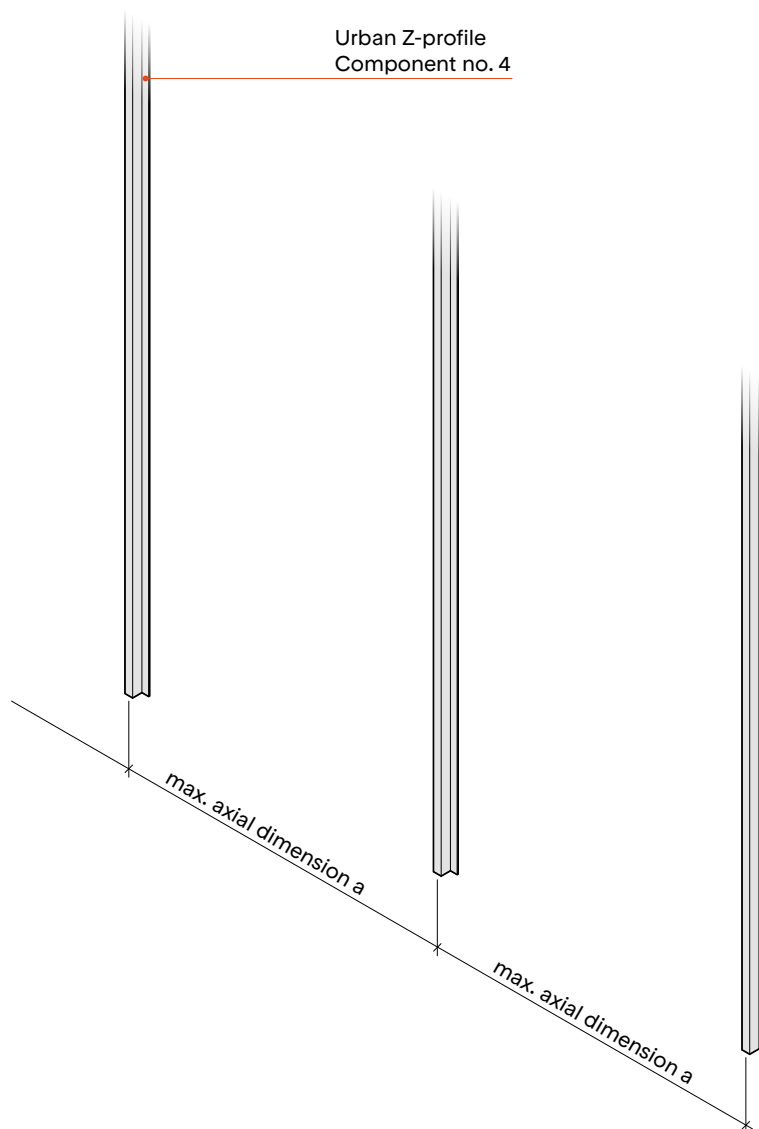

See p. 13 for max. axial spacing

- 2.** First, attach the Urban Beginner profile to the Z-profiles at the base of the façade.
The Urban self-drilling screws 4.8 × 16 mm are to be used.

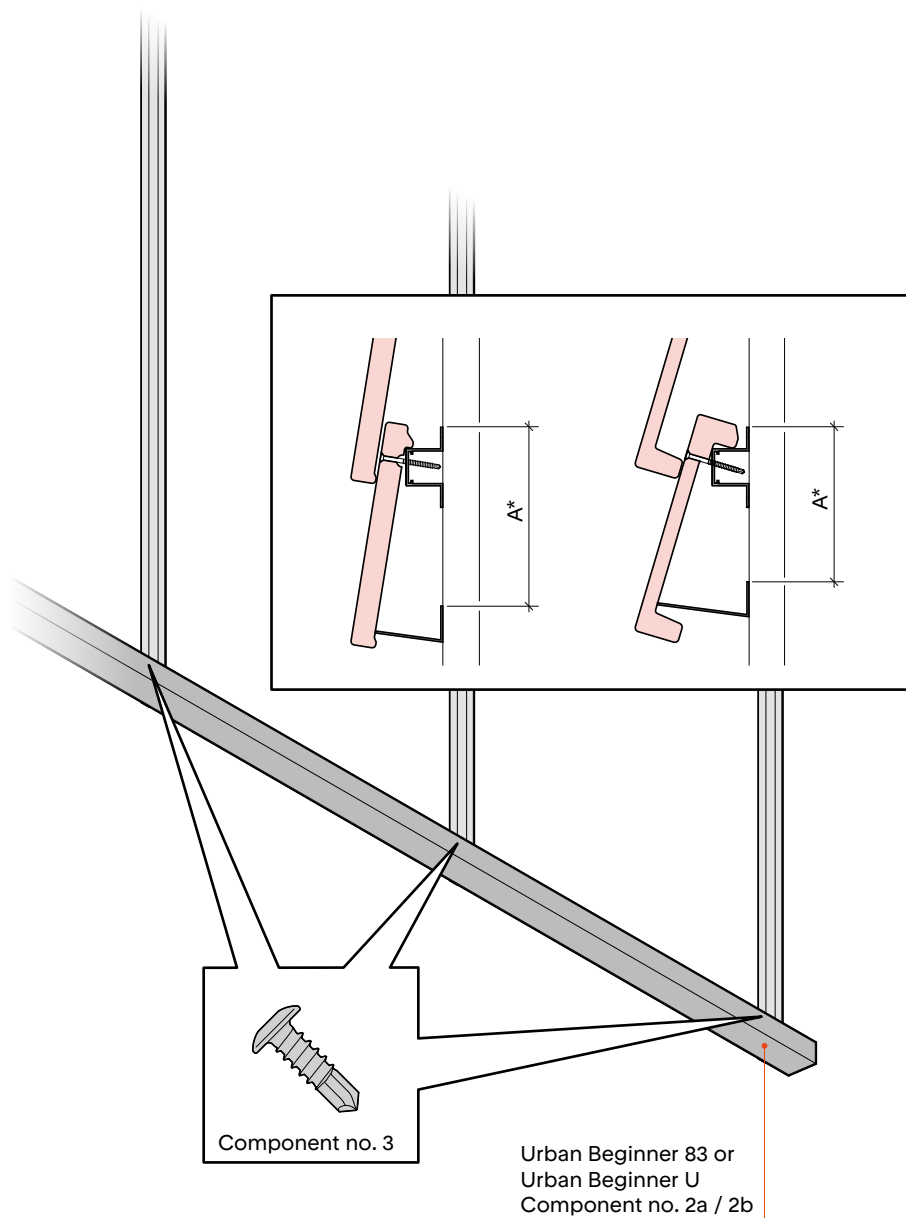

* Dimension A see p. 14/15

- 3.** Affix the Omega support battens at a regular spacing.
The Urban self-drilling screws 4.8×16 mm are to be used for this.
The butt joint should be created alternately in a different field.
A distance of 10 mm must be retained between two profiles as dilatation joint.
The fastening plate serves as an assembly aid.

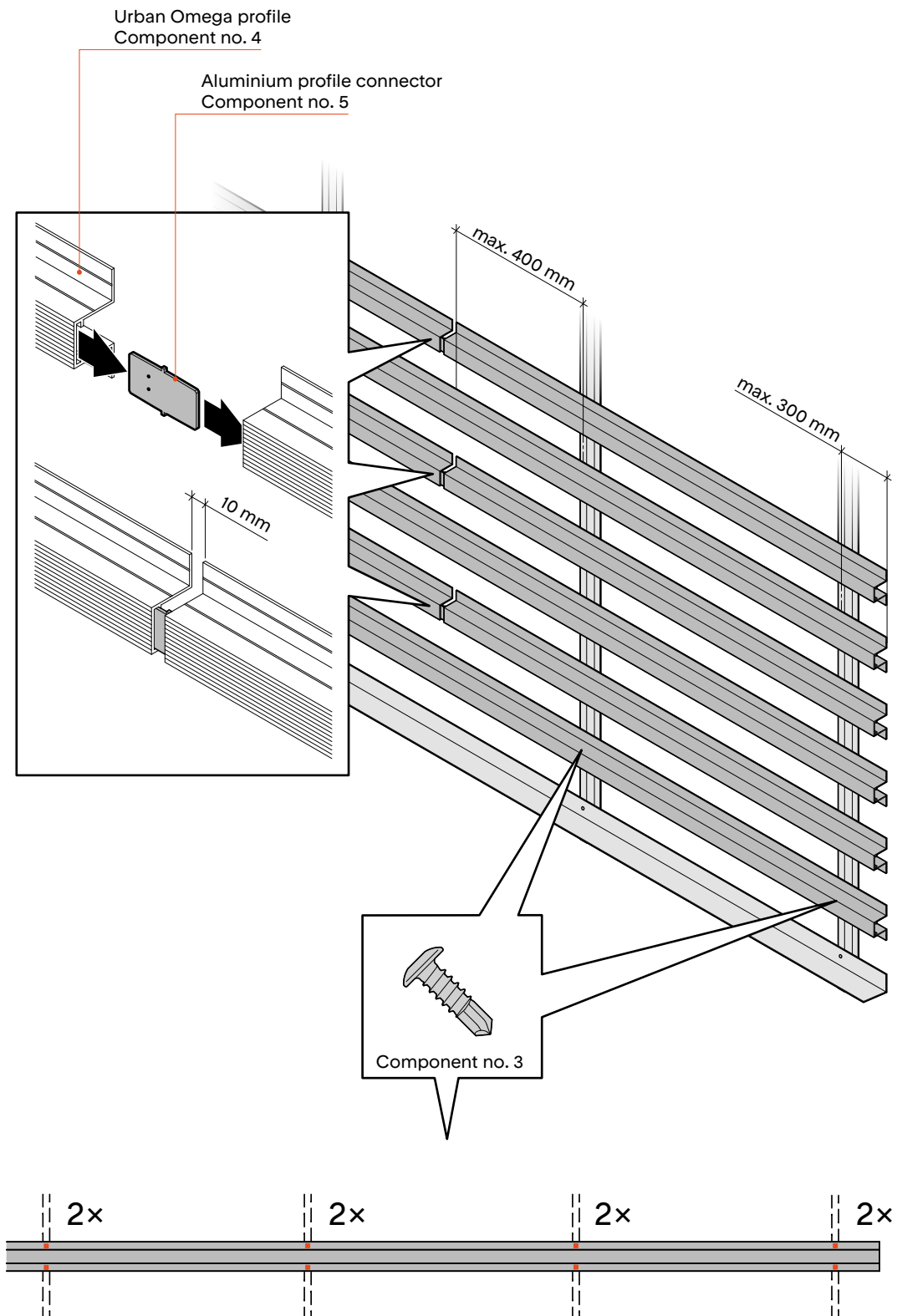

- 4.** Hook the Urban cladding tiles individually and with blunt sides lateral onto the support profiles and secure immediately with 2 Urban self-drilling screws 4.2 × 48 mm. Joints should be a hair's breadth across.

⚠ A tile that is mounted across the joint of an Omega aluminium profile must be attached to only one of the profiles. (different degrees of expansion)

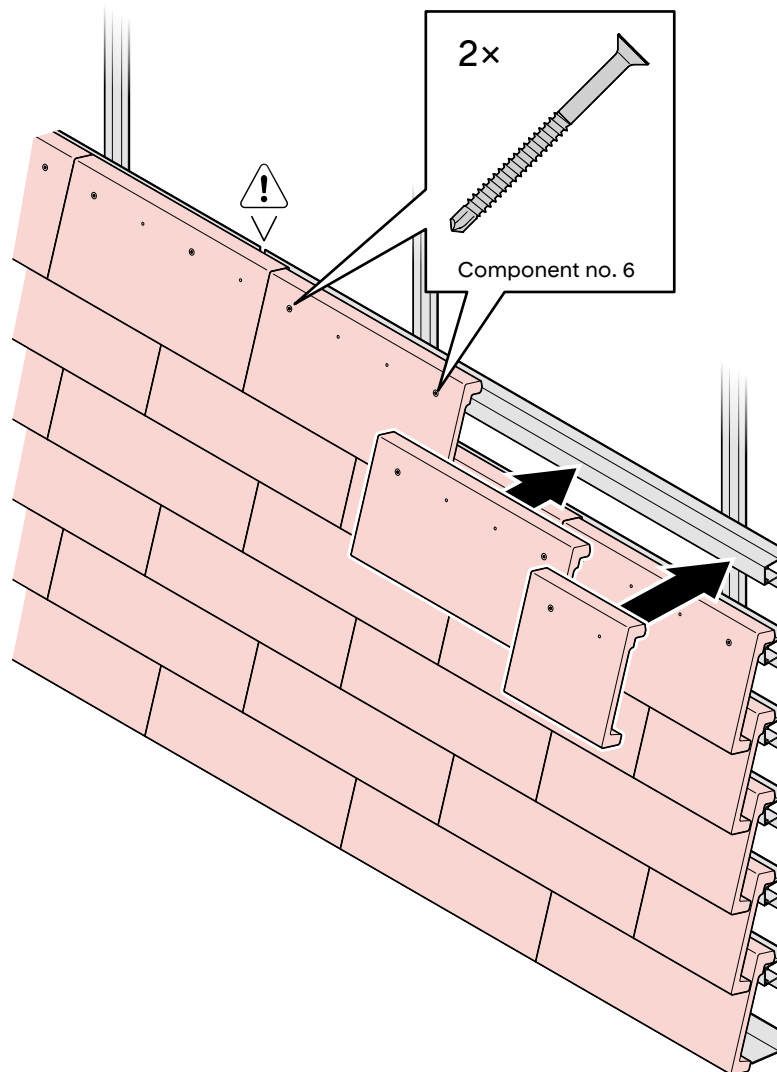

Replacement and subsequent installation of individual tiles on the surface

In particular when using façade scaffolding, it may be necessary to fit individual tiles at a later stage.

1. Cleanly remove tile without damaging any others.

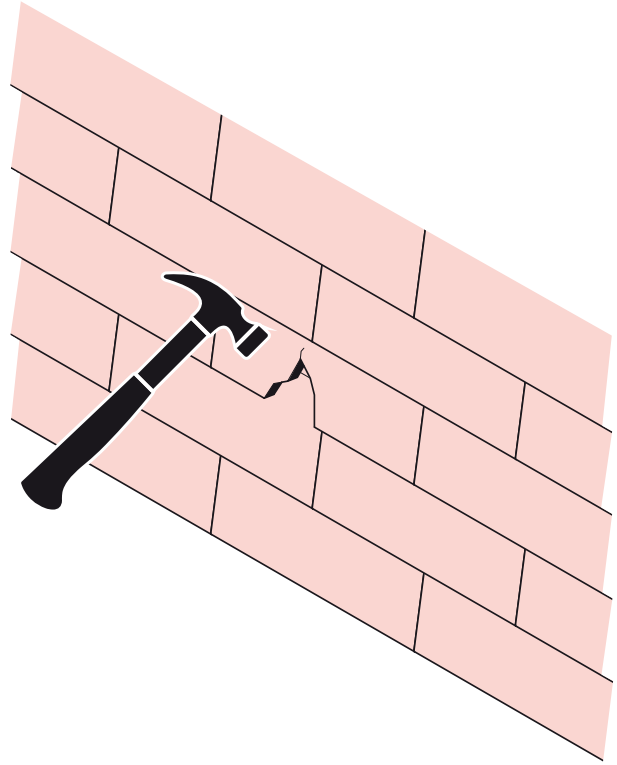

2. Cleanly remove the existing screws.

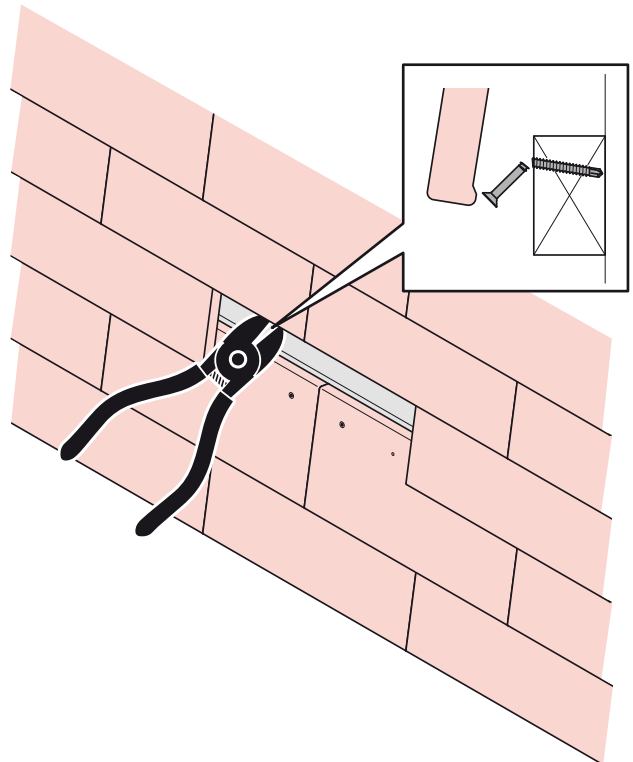

- 3.** Use suitable shims to slightly raise the tiles above.

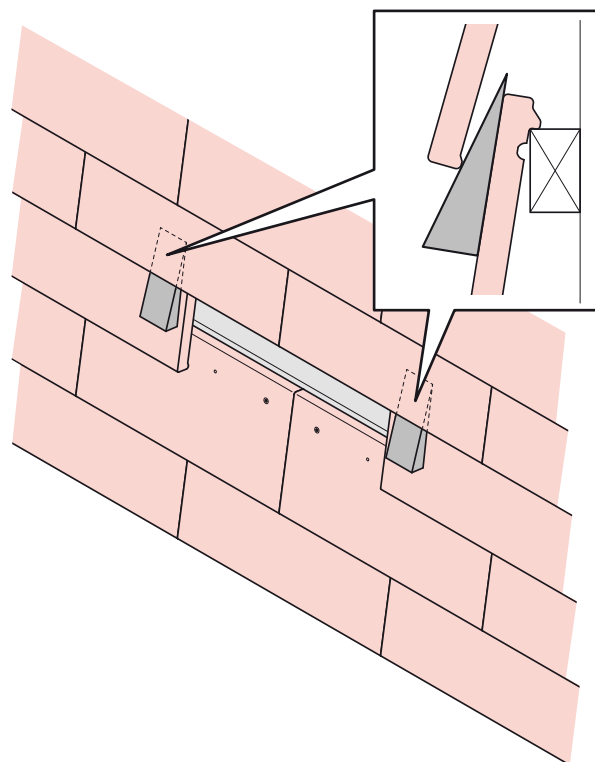

- 4.** In the case of the Urban U-type, the hanging lug must be reduced to 5 mm.

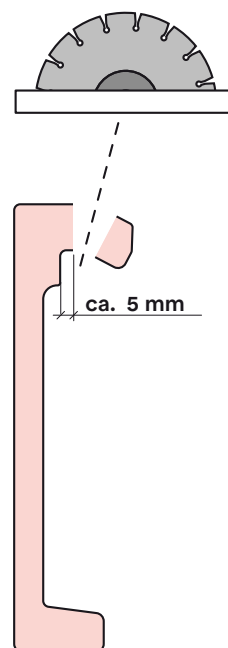

5. Hook on the new tile.

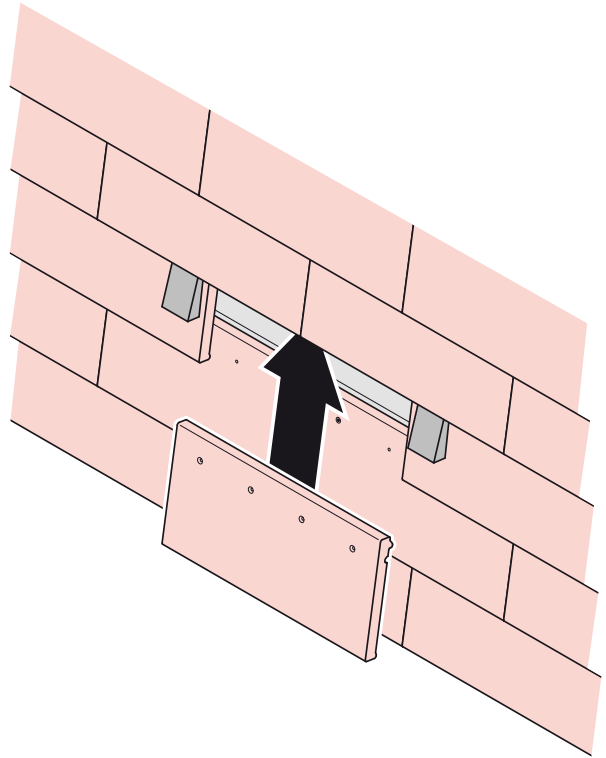

6. Secure the new tile using a visible façade screw with an EPDM washer.

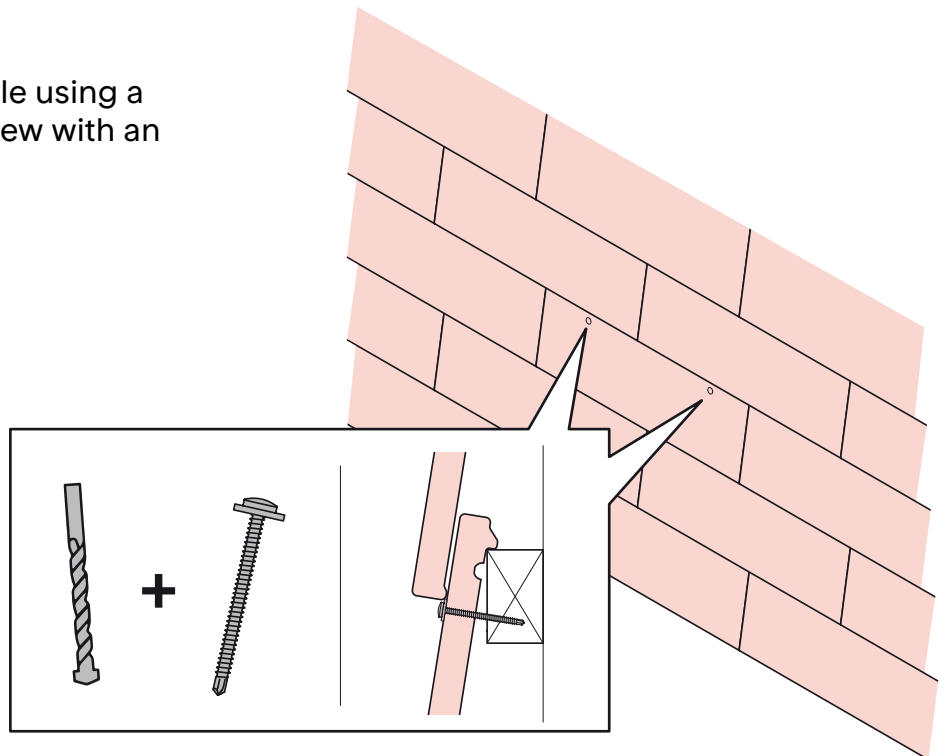

- (7.)** Optionally, the tile can also be secured using a suitable construction adhesive. This means there will be no visible screws later on.

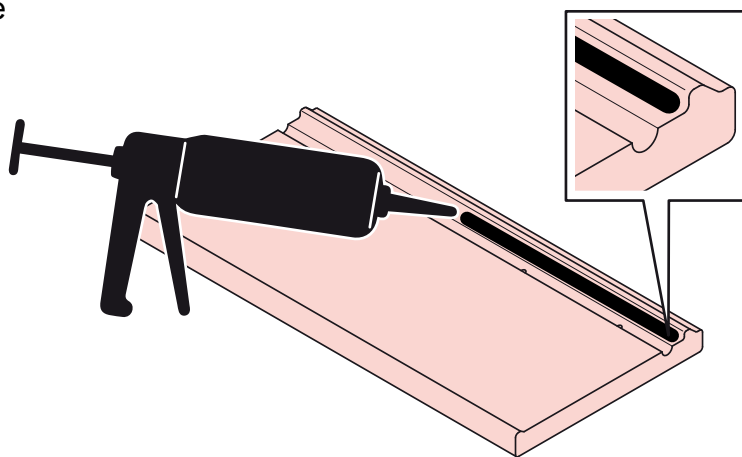

Installing aluminium joint barriers

The 100 × 180 mm aluminium joint barriers are to be used on the roof. (Component no. 8)

1.

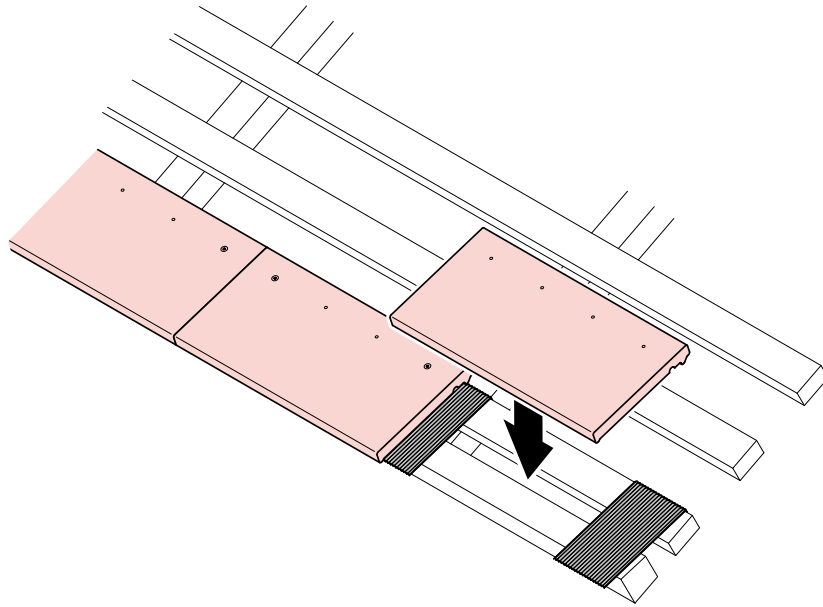

2.

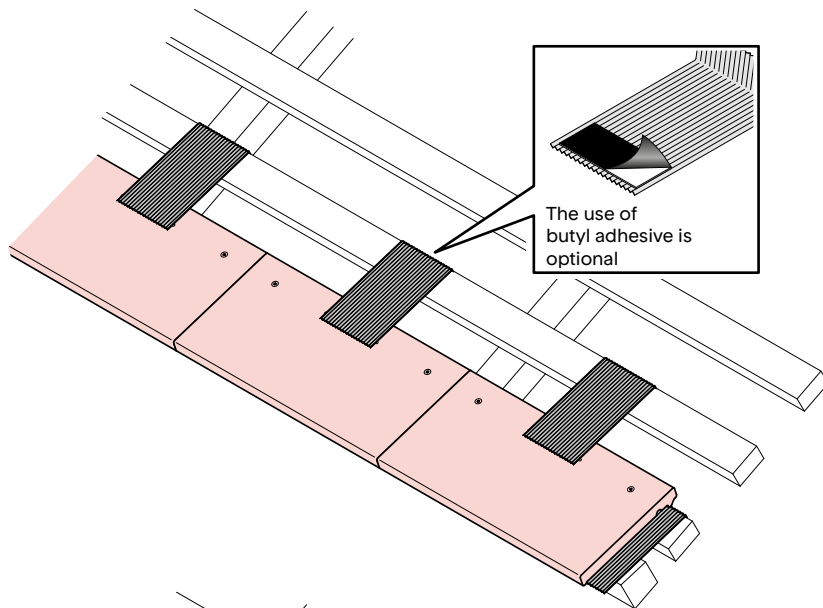

3.

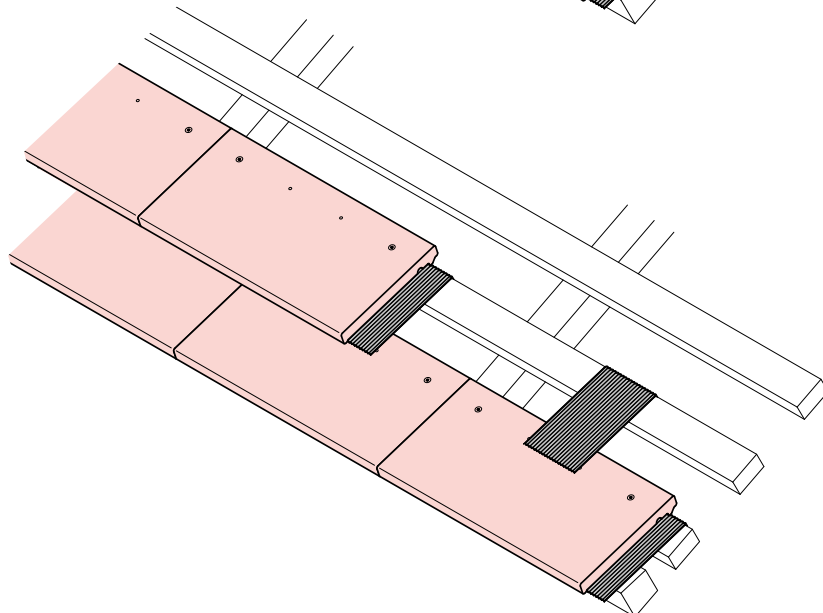

Installing a snow guard system

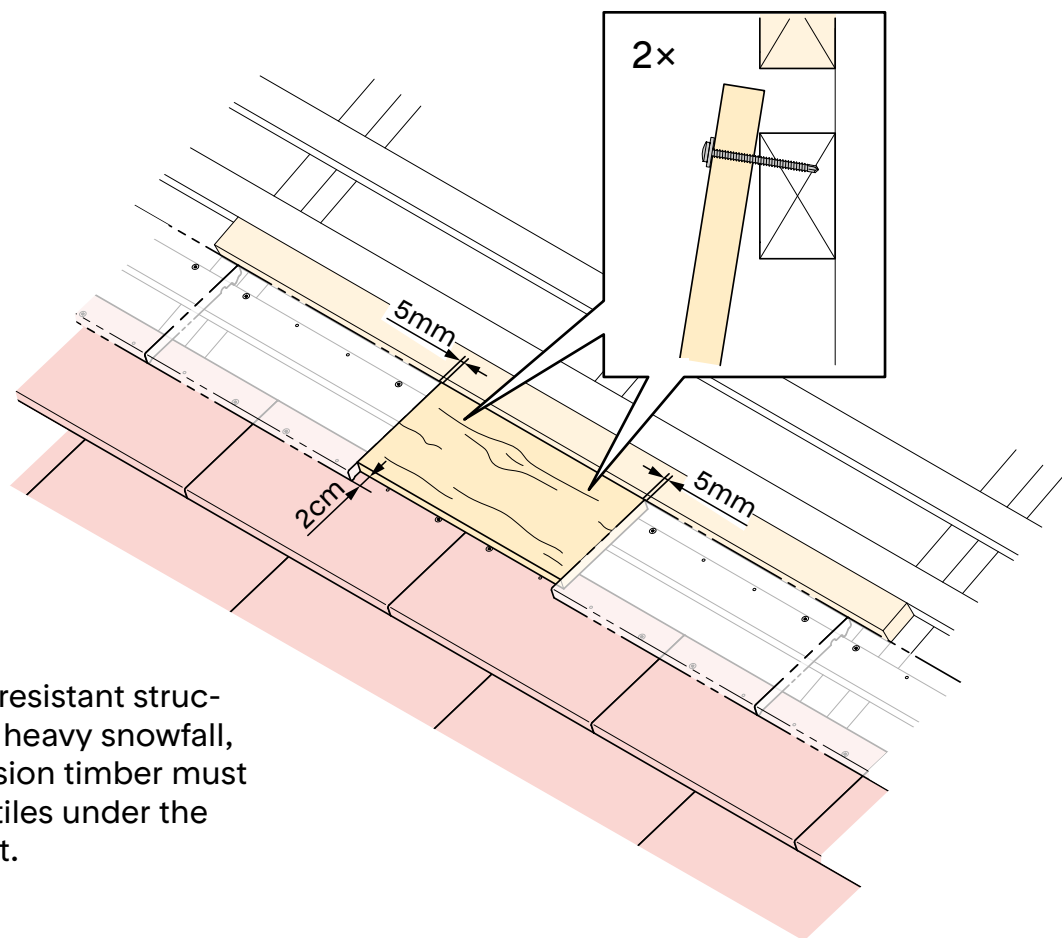

1. For a compression-resistant structure in regions with heavy snowfall, a suitable compression timber must be used instead of tiles under the snow guard support.

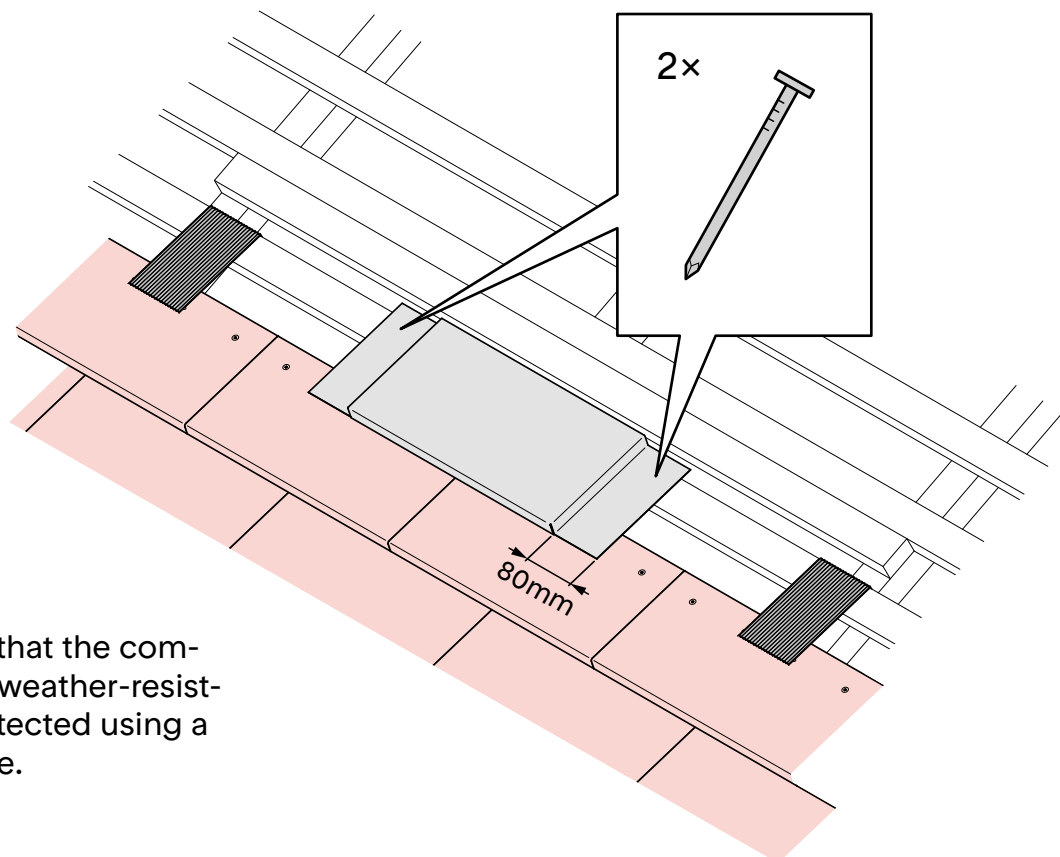

2. In order to ensure that the compression timber is weather-resistant, it must be protected using a suitable cover plate.

- 3.** In order to avoid damage to the plate, the hanging lugs behind it on the tile are removed selectively.

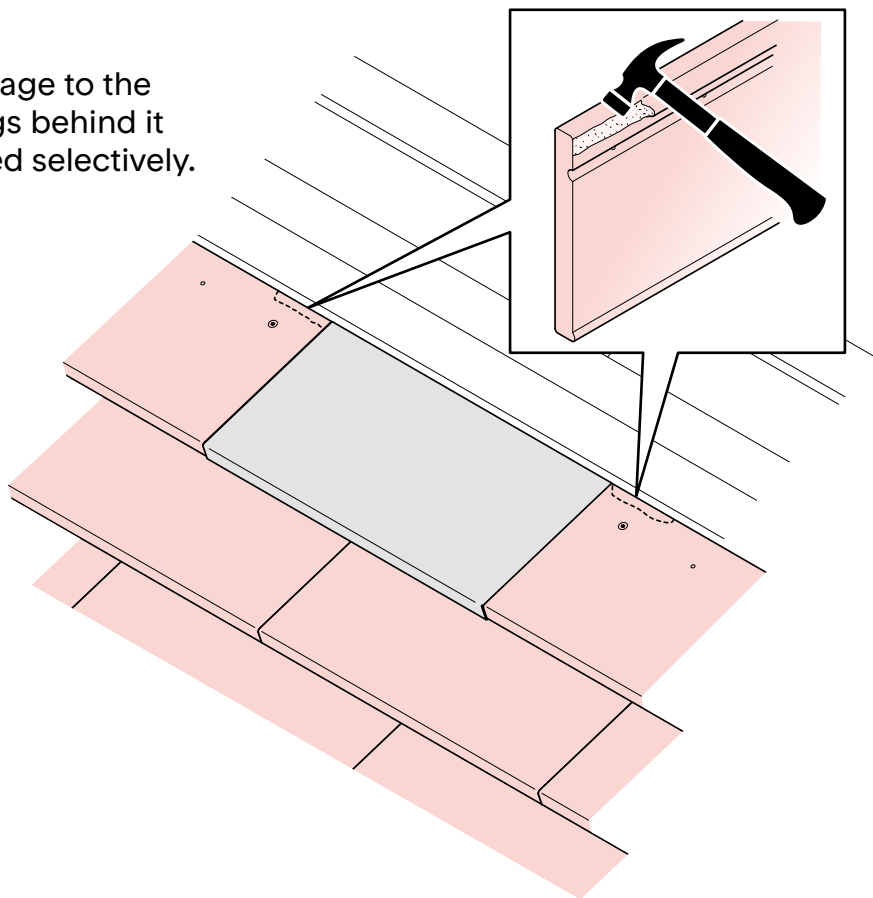

- 4.** The snow guard support must be anchored in the supporting structure.

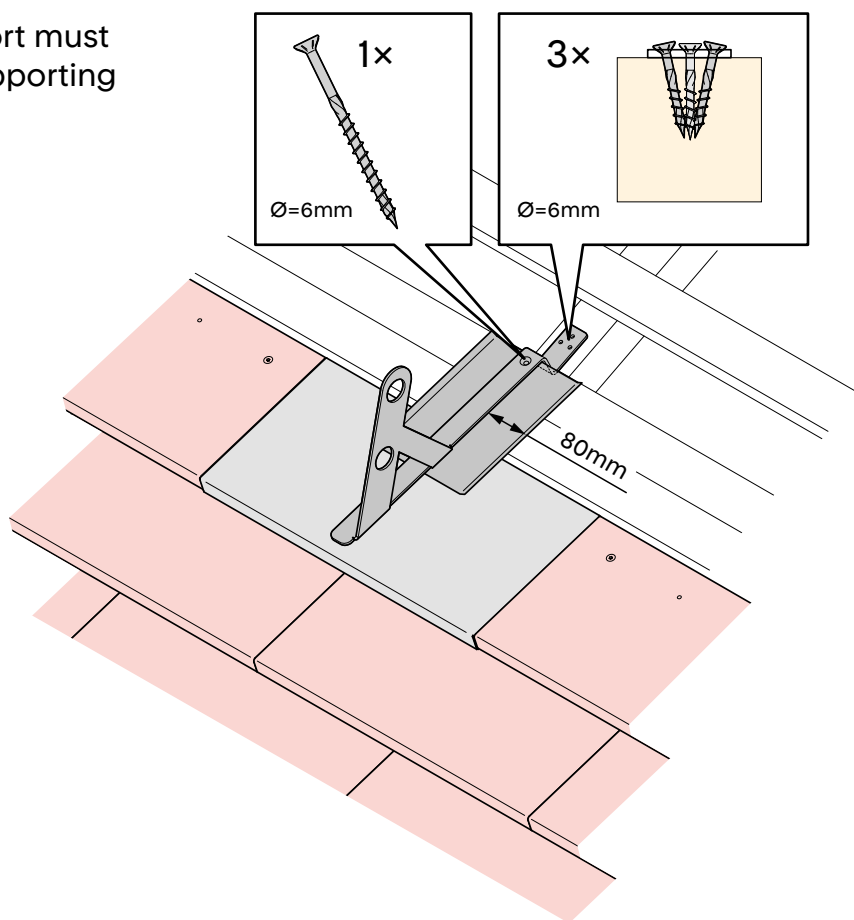

5.

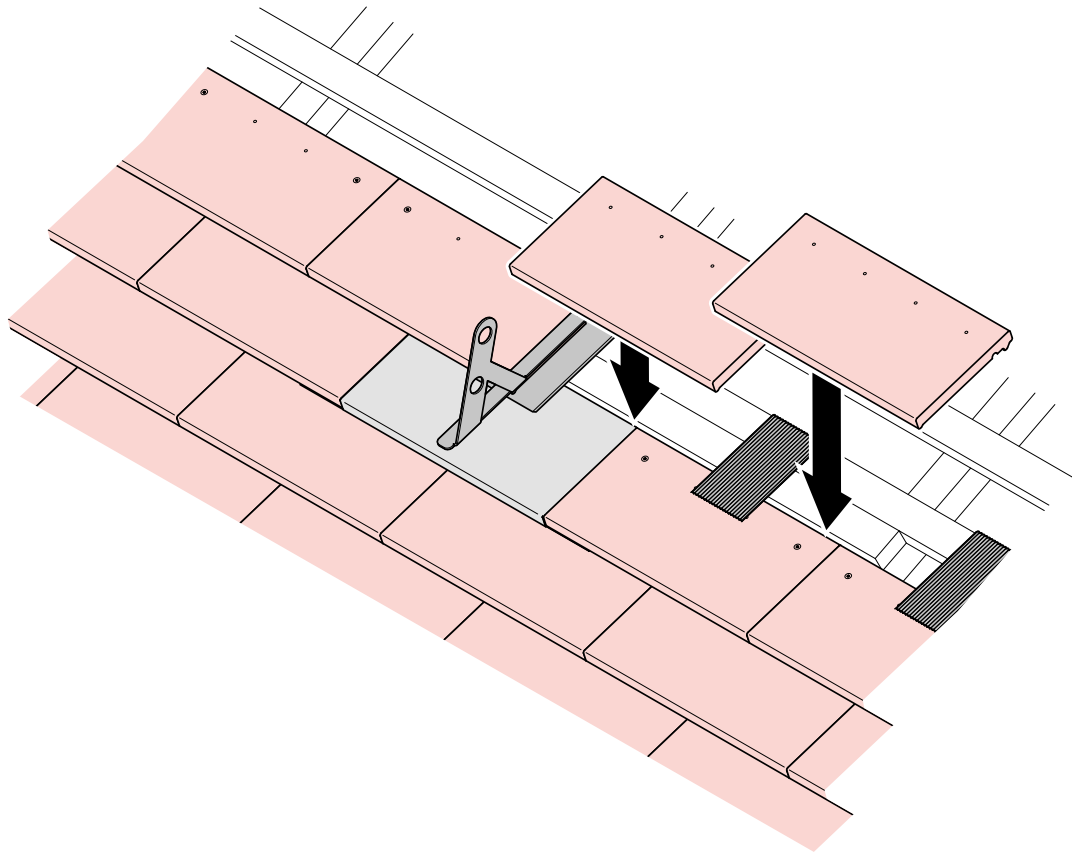

Tools / Machines

- Roofing hammer
- Masonry drill bit Ø 5 mm
- Sheet metal cutters
- Wet cutter with diamond blade
- Tile hammer
- Cordless screwdriver
- Angle grinder / diamond blade Ø 230 mm
- Clamping pliers

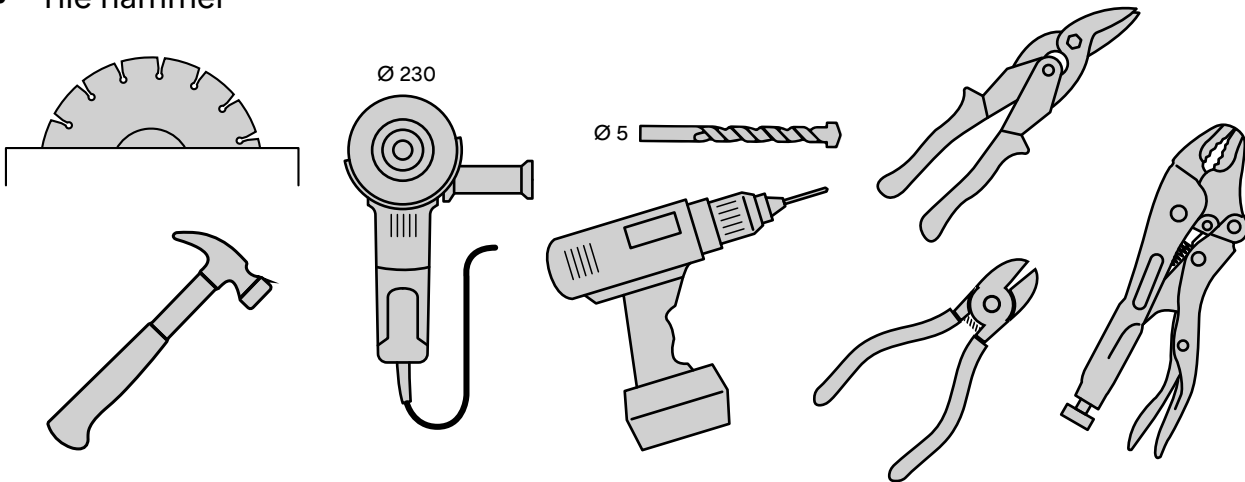

Occupational safety

Wearing safety glasses, a helmet, gloves, hearing protection and a dust mask is mandatory; these must be used when cutting ceramic materials. To ensure safety on the construction site, it is recommended to wear helmets, safety glasses and gloves while carrying out installation work. Take the necessary precautions when working at height. The currently valid regulations must be observed.

Cleaning

During the installation of Urban clay cladding tiles, drilling, cutting and grinding dust as well as dirt from the scaffolding and the surrounding area can end up on the façade. The dirt deposits consist of coarse, sand-like and fine dust-like particles, which also contain lime and salt compounds. Exposure to moisture can result in visible, permanent discolouration of these deposits, which has a negative impact on the overall aesthetic effect.

Cleaning recommendation:

- Remove drilling, cutting and grinding dust immediately after carrying out the work. Clean with water
- At the end of the day, clean with compressed air or light water jet pressure
- Final cleaning must be carried out immediately before dismantling the scaffolding. Clean the cladding tiles with cold water jet pressure (40–60 bar) and a soft plastic brush if necessary.

Important: never clean in full sunlight!

Maintenance

On the façade: It is recommended to conduct a visual inspection of the façade once a year in order to identify any damage. Otherwise, no special measures are needed.

On the roof: Conduct a visual inspection at least once a year, in particular to look for signs of damage at the transition points. Defective tiles must be replaced. In the event of recurring problems in heavy snow, snow guards should be retrofitted in order to prevent ice and snow from sliding down. When using snow guards, make sure that they have the correct dimensions.

Maintenance: no regular maintenance required.

A layer of lichen and green lime may form on the surface of untreated tile products (patina), in particular if there are large trees or other vegetation in the immediate vicinity. This patina does not impair the quality or the frost resistance of the tiles. However, if desired it can be removed with moss killers, water jet (max. 40–60 bar) and a broom.

Requirements / Standards

- Standard SIA 232/1 on pitched roofs
- Standard SIA 232/2 on rear-ventilated cladding of external walls
- Guideline for the planning and execution of rear-ventilated curtain façades (“Richtlinie für die Planung und Ausführung von vorgehängten hinterlüfteten Fassaden”) from IFD-Service GmbH

Additional requirements for use in Germany

Owing to their compliance with the following three requirements, no special permit is required

for the construction of Urban U and L cladding tiles:

- As per DIN 18516, the surface area is $\leq 0.4 \text{ m}^2$
- As per DIN 18516, the weight is $\leq 5 \text{ kg}$
- Installation complies with the recognised rules of technology.

Urban cladding tiles on wood and aluminium substructures are to be installed in accordance with the rulebook of the German Central Association of the Roofing Trade (Zentralverband des Deutschen Dachdeckerhandwerks, ZVDH).

The use of the Urban U and L cladding tiles complies with the recognised rules of technology; no project-related type approval (vBG) or general type approval (aBG) is required.

Notes

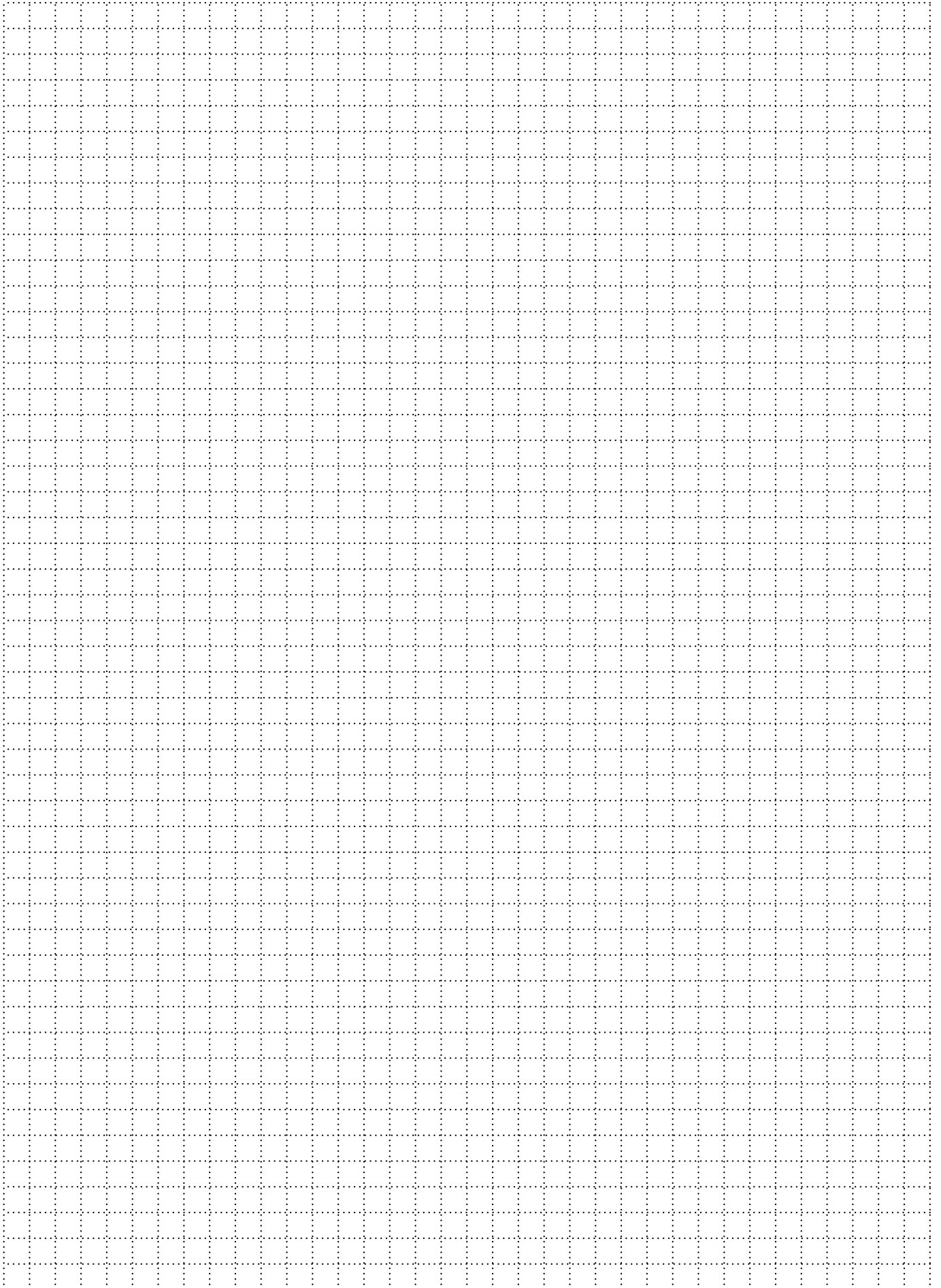

Service

Everything you need for your project:

- Detailed drawings
- CAD drawings and textures
- Technical data sheets
- Documentation on planning and execution

You can download all data here:

urban.zz-ag.ch

If you have any questions, our building consultants will be happy to help:

info@zz-ag.ch

+41 58 219 09 09

Published by: Zürcher Ziegeleien

Editorial team: Roman Knuchel, Ronny Egli, Per Ivar Odegaard

Design: Clough Graphic Design

Photography: Oliver Ernst

© Zürcher Ziegeleien AG, June 2022

Zürcher Ziegeleien offers ceramic solutions for the entire building envelope. For over 150 years, we have been making homes more natural and building easier with our clay building materials. We use a simple raw material to develop sophisticated systems for roofs, walls and façades. We have been part of the swisspor Group since 2020.



Zürcher Ziegeleien AG
Eichwatt 1, 8105 Regensdorf
Switzerland

Phone +41 58 219 09 09
info@zz-ag.ch
www.zz-ag.ch